

# Session #: MT0003

## Solid-State Lighting

---

Dr. John W. Curran  
LED Transformations, LLC

# Copyright Materials

---

This presentation is protected by US and International copyright laws. Reproduction, distribution, display and use of the presentation without written permission of LED Transformations, LLC is prohibited

---

Reed Construction Data is a Registered Provider with The American Institute of Architects Continuing Education Systems. Credit earned on completion of this program will be reported to CES Records for AIA members. Certificates of Completion for non-AIA members are available on request.

This program is registered with the AIA/CES for continuing professional education. As such, it does not include content that may be deemed or construed to be an approval or endorsement by the AIA of any material of construction or any method or manner of handling, using, distributing, or dealing in any material or product. Questions related to specific materials, methods, and services will be addressed at the conclusion of this presentation.

# Learning Objectives

## Solid-State Lighting

---

1. Concepts unique to LED technology such as directionality
2. The critical link between thermal management and lifetime
3. How to choose wisely when selecting LED-based luminaires

# Course Outline

---

1. Introduction – Why should I care about LEDs?
2. What's different – LED technology as compared to traditional light sources
3. Technology Limitations – Characteristics to be aware of with solid-state lighting
4. Environment – Its effect on LEDs
5. LED Products – Where to turn for guidance
6. Applications – Good ones and bad ones
7. Final Thoughts – Some general rules

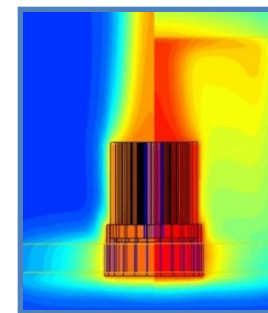

# Introduction

## Why Should I Care About LEDs?

---

- By 2030 the US Department of Energy has estimated that LED technology has the potential to produce yearly energy savings of 190 terawatt-hours
  - Equivalent of 24 large (1,000 MW) power plants
  - Reduction of 25% of present energy consumption for lighting
  - Equates to approximately \$15 billion savings in today's dollars
- Spanning 2010 – 2030, the cumulative energy savings are estimated to total approximately 1,488 terawatt-hours
  - Representing approximately \$120 billion at today's energy prices
  - Over that same time period, greenhouse gas emissions would be reduced by 246 million metric tons

# Introduction

## Why Should I Care About LEDs?

LEDs are like no other conventional lighting source

- + Potentially longest<sup>1</sup> life of any lighting sources
- + Very high energy efficiency
- + Small size and instant on allows new applications
- + Produces color light directly without filtering
- + Integrates well with other semiconductor electronic elements
- Thermal management requirements
- Cost
- New technology brings unfamiliar issues to architects, lighting designers, building owners and facilities managers



=

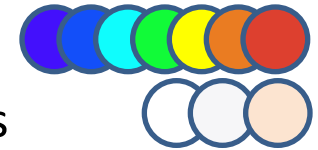

<sup>1</sup>Note: Some manufacturers have introduced products claiming long lifetimes: fluorescent tubes (40,000 hours); induction (100,000 hours)

# Introduction

## Why Should I Care About LEDs?

LED market growth over the next 3 years

APPLICATION SEGMENTS  
2008 – 2013

Source: Vrinda Bhandarkar  
Strategies Unlimited

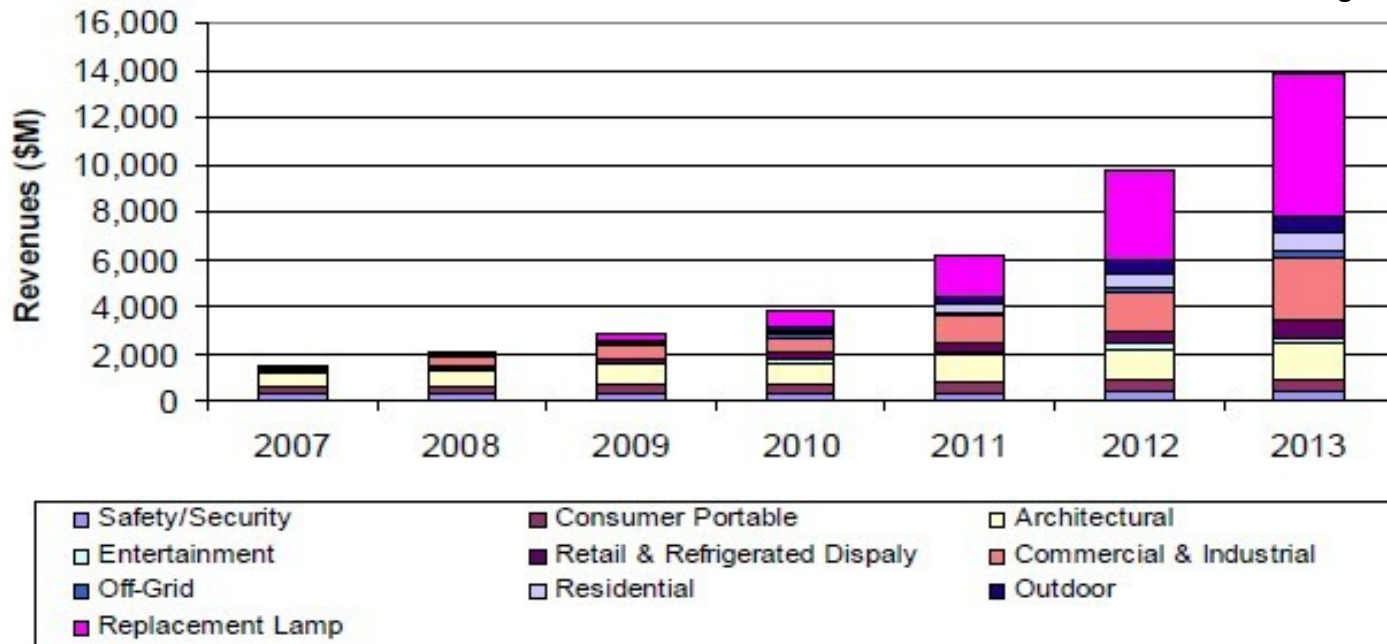

# Introduction

## What have you heard about LEDs?

---

- They don't produce any heat
- They last forever
- Anyone who isn't installing LED-based products everywhere is foolish
- There is a conspiracy to limit the use of LEDs
- There is a conspiracy to force the use of LEDs
- They don't work
- They are too expensive

# Introduction

## What is the truth about LEDs?

---

- They **do** produce heat – just not as much
- They **don't** last forever – just longer than other sources
- Anyone who isn't considering installing LED-based products for some applications is foolish
- They don't work if misapplied
- They are expensive but costs continue to drop
- There is a conspiracy by physicists to force the metric system on everyone having nothing to do with LEDs

# Introduction

## What is an LED?

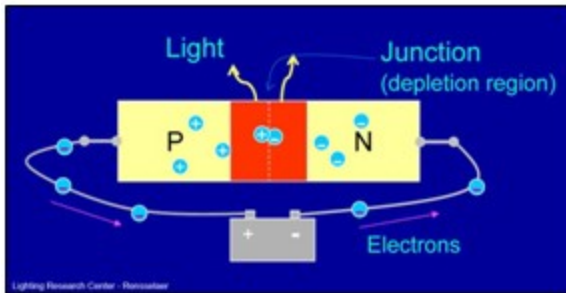

An LED (**L**ight **E**mitting **D**iode) consists of a chip of semiconducting material treated to create a structure called a p-n (positive-negative) junction

The heatsink is what allows the high flux LED to generate much more light

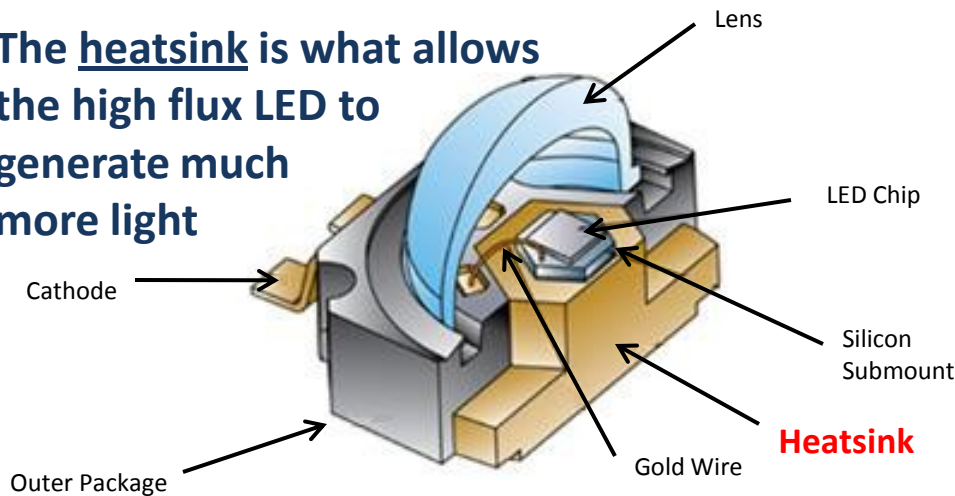

Diagram of a high flux LED

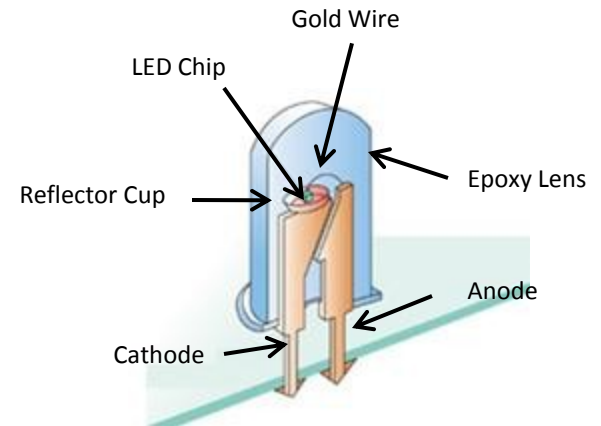
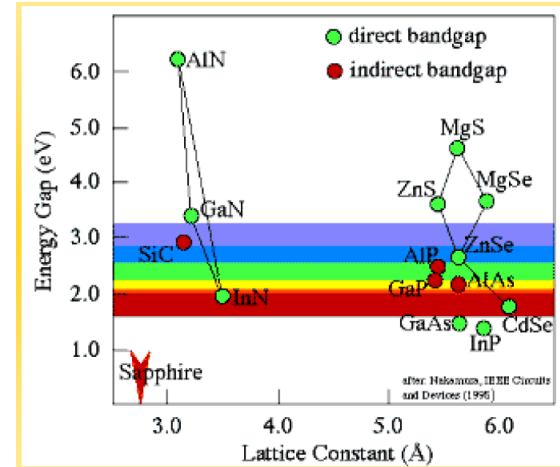
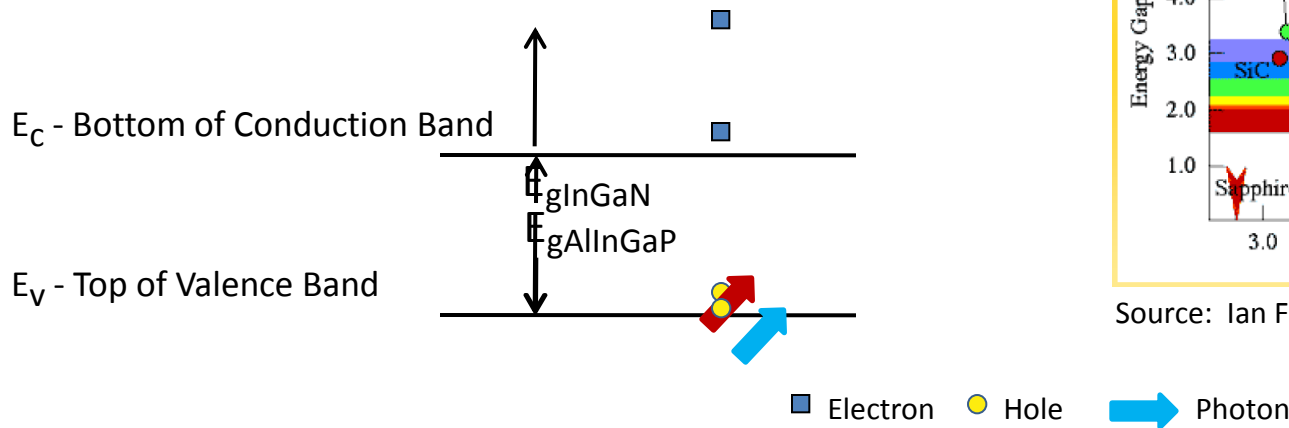

Diagram of a 5mm LED

# Introduction

## How does the LED make light?

Bandgaps – Different gaps, different colors



Source: Ian Ferguson, NC University

Smaller bandgap → Lower energy → Longer wavelength photon → Red

Larger bandgap → Higher energy → Shorter wavelength photon → Blue

# Introduction

## How does the LED make light?

Sometimes it works – Radiative Recombination

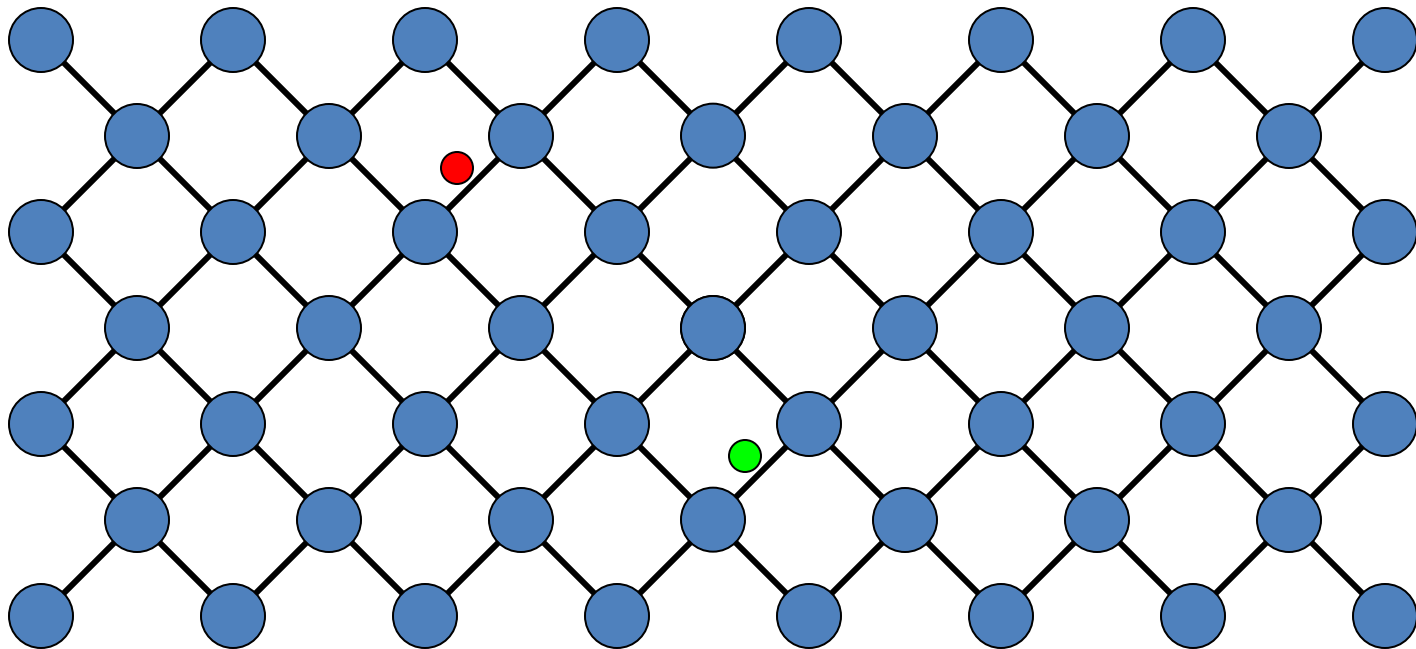
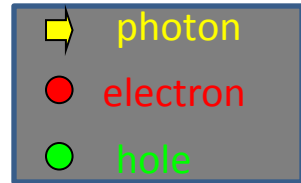

# Introduction

## How does the LED make light?

Sometimes it doesn't – Non-radiative Recombination

Creates heat instead of light

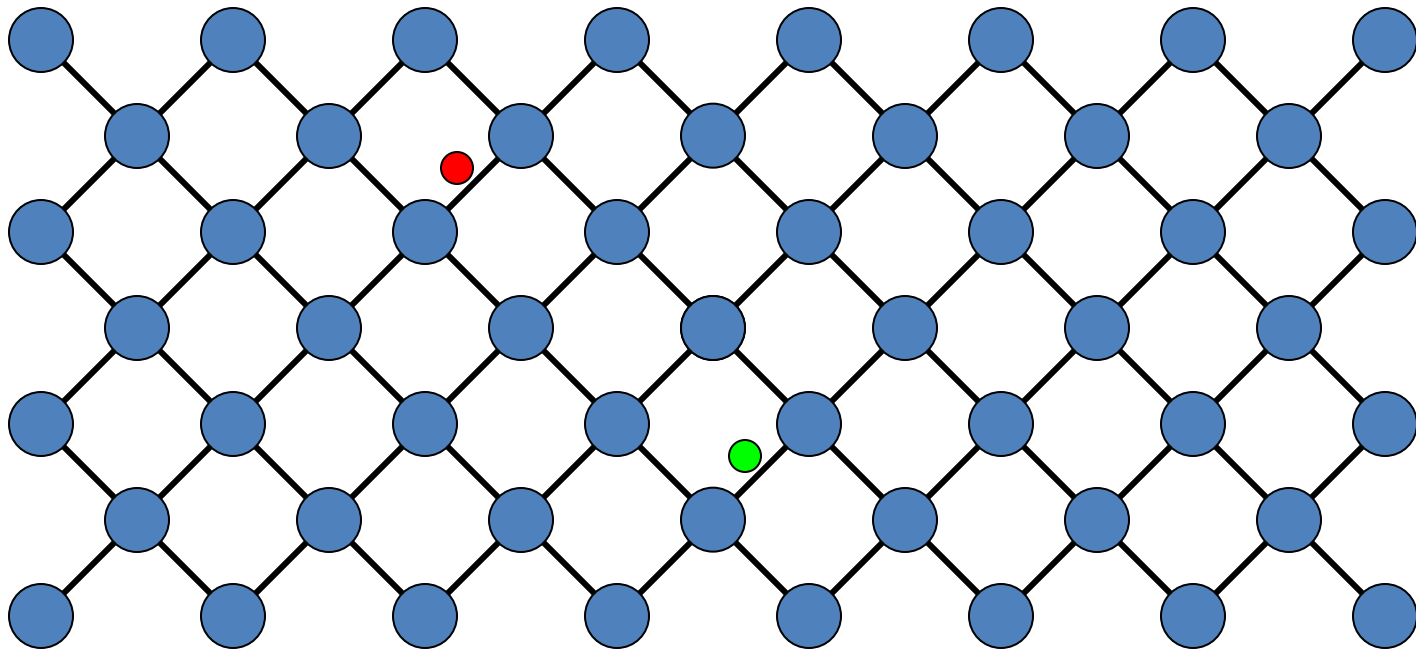
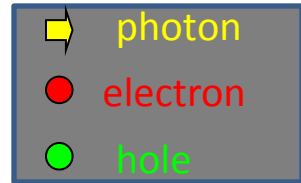

# Introduction

## How does a white LED work?

### Downconverting Phosphor

- Blue LED + YAG **Cool White**
- Blue LED + YAG + Other phosphor (red, green, etc.) **Warm White**
- UV LED + Red phosphor + Green phosphor + Blue phosphor

Convention Coating

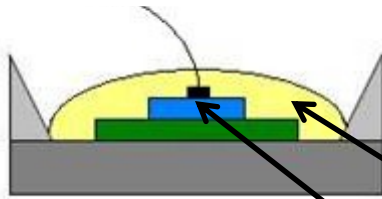

Conformal Coating

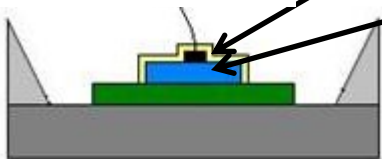

Phosphor

InGaN Die

Cool White LED Spectra

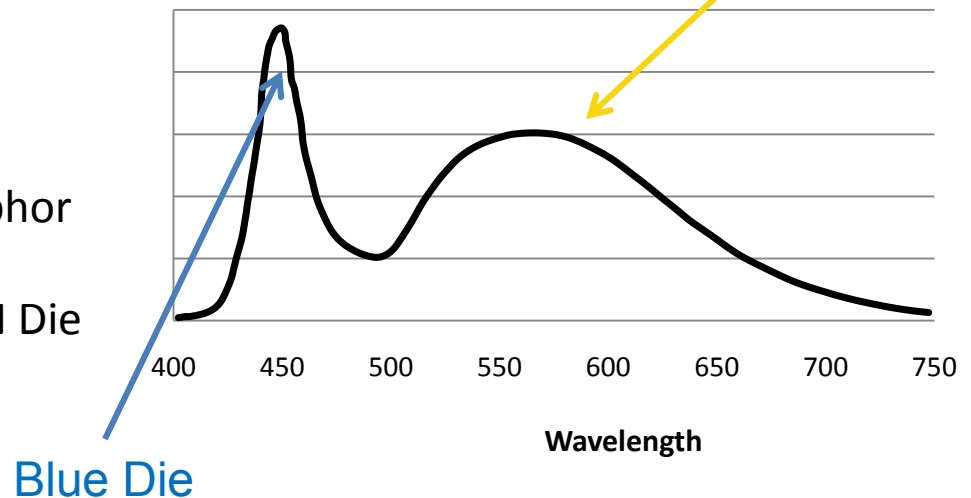

# Course Outline

---

1. Introduction – Why should I care about LEDs?
2. What's different – LED technology as compared to traditional light sources
3. Technology Limitations – Characteristics to be aware of with solid-state lighting
4. Environment – Its effect on LEDs
5. LED Products – Where to turn for guidance
6. Applications – Good ones and bad ones
7. Final Thoughts – Some general rules

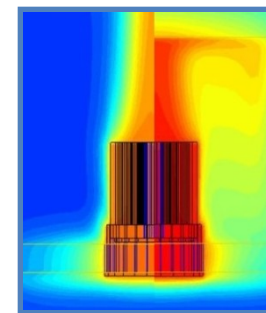

# What's Different

## Long Lifetimes

- Traditional light sources fail catastrophically due to electrodes which weaken or become contaminated and eventually fail, causing the lamp to stop working
- LEDs rarely fail catastrophically
  - Light output gradually decreases over operating time
  - End of life defined to be when light output reaches 70% of initial value
    - Raises issue for designers – how to warn users that product has exceeded end-of-life and is producing less light than the application may require
  - Lifetime highly dependent on temperature (ambient and device as well as operating current)

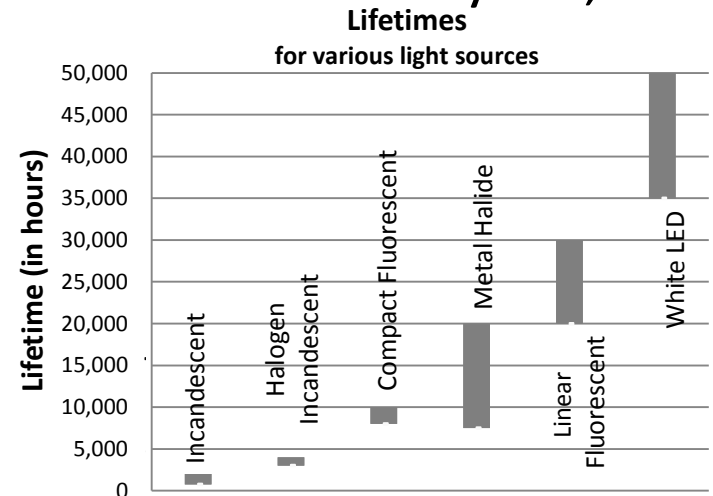

# What's Different

## Long Lifetimes – A Measurement Issue

- It is difficult to predict the long term performance of a device with only early lifetime data

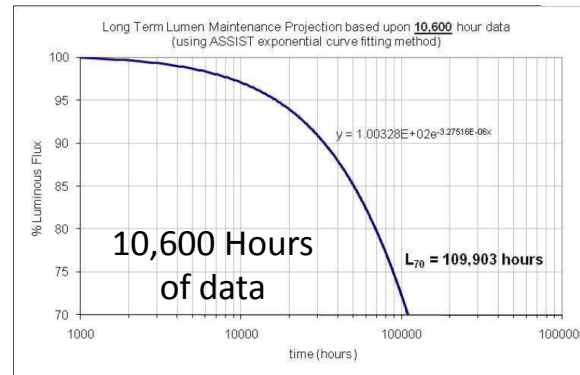
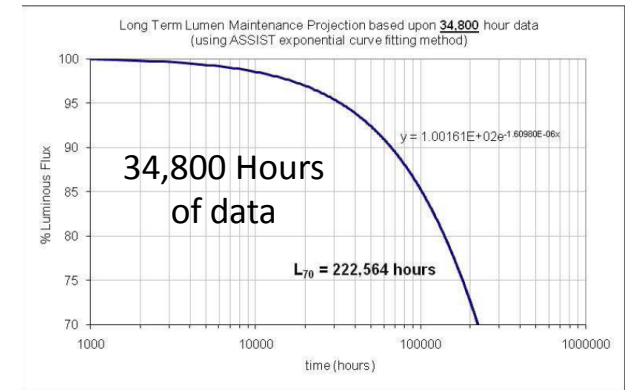
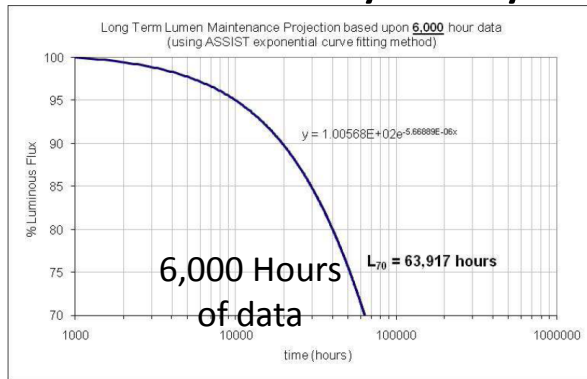

**Almost 3.5 X's longer predicted lifetime than the 6,000 hour results**

Source: Cree

# What's Different

## Highest Energy Efficiency

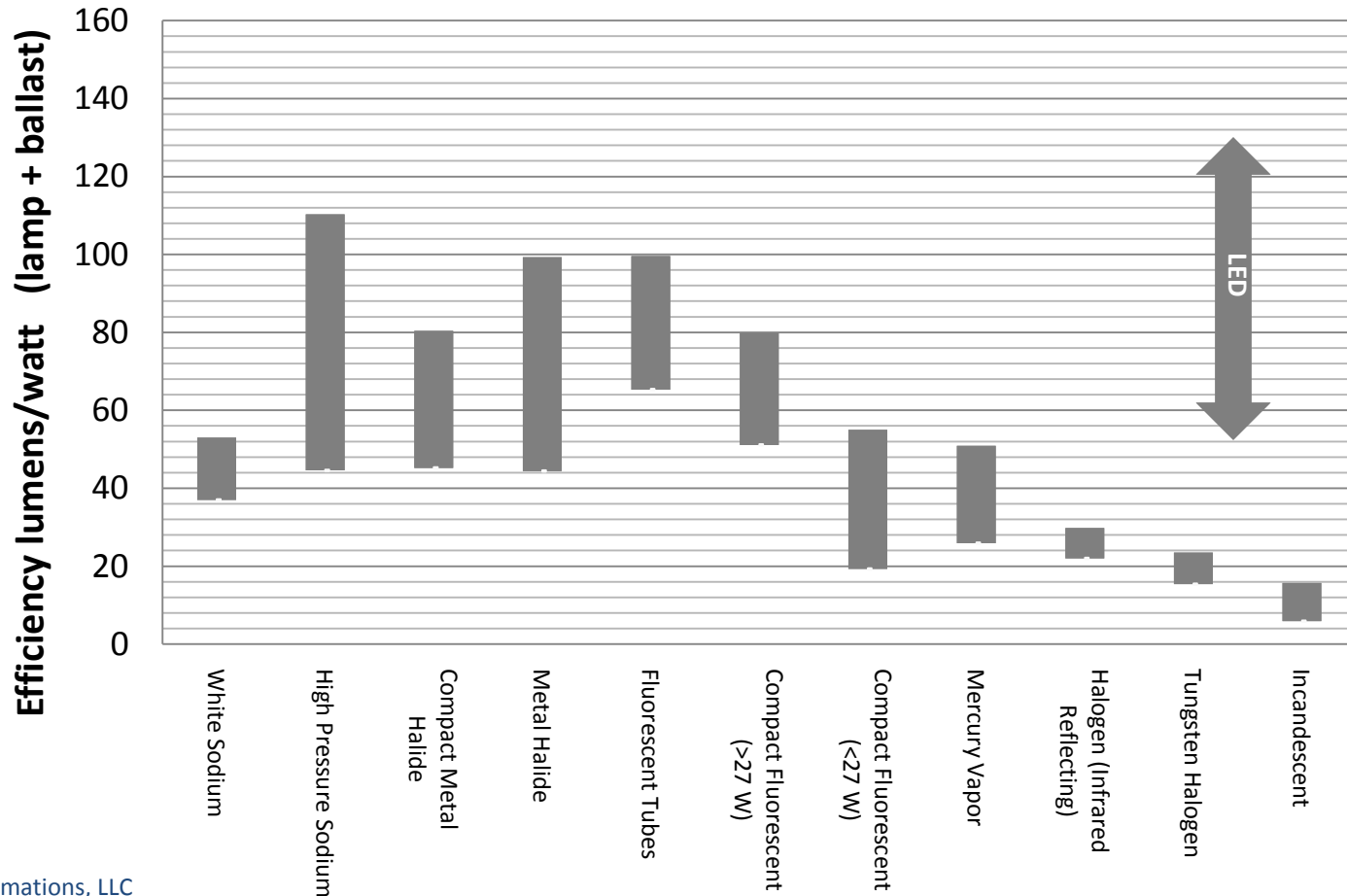

# What's Different

## Small Size



T5 Fluorescent  
1350 lumens

75W PAR 38 Halogen  
1100 lumens



75W Incandescent  
1200 lumens



Cree MP-L LED  
1200 lumens

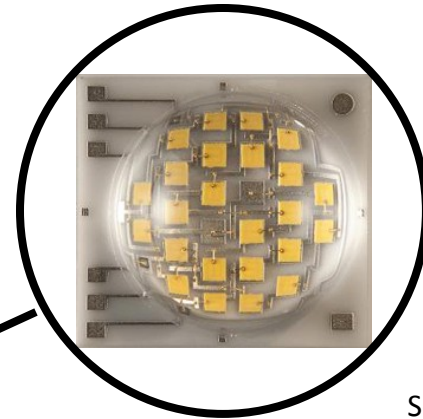

Source: Cree

# What's Different

## Rate of Development

LEDs follow a development rule known as Haitz's Law

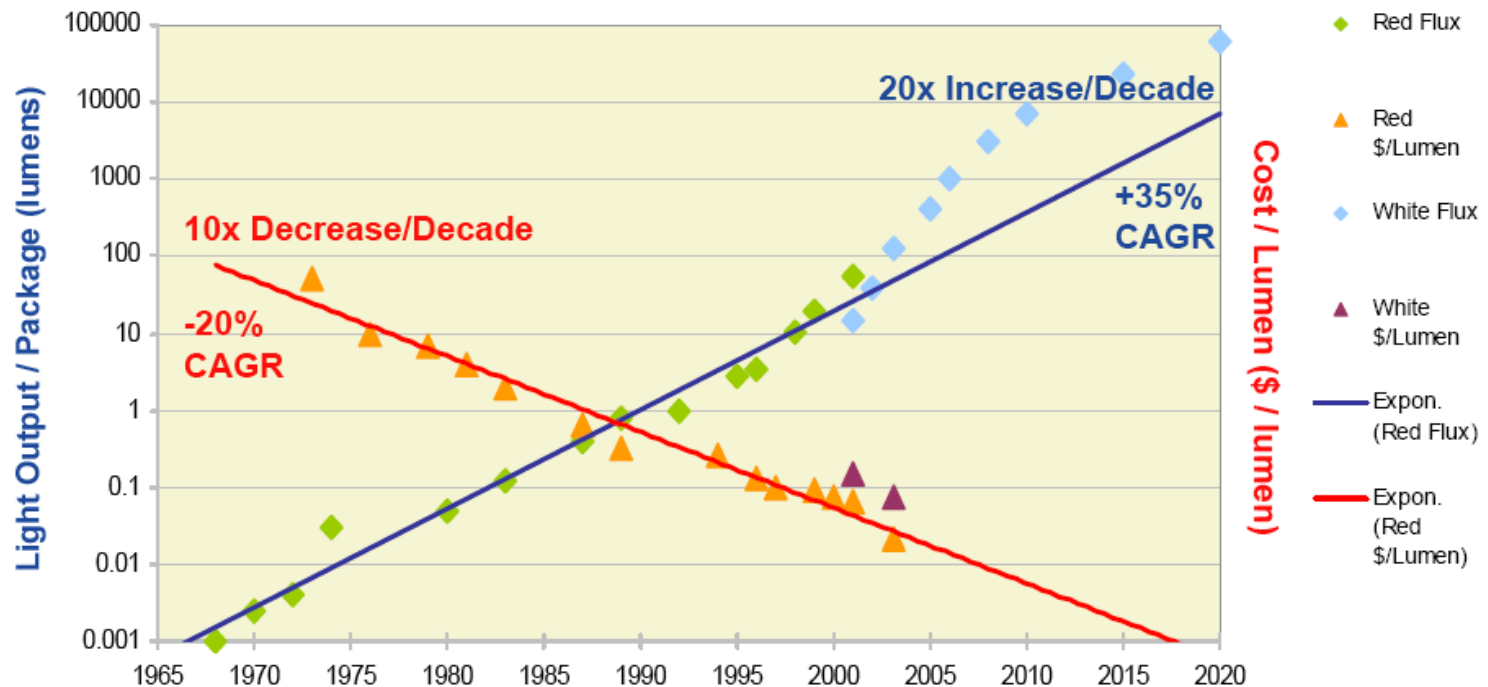

Source: Roland Haitz & Lumileds

# What's Different

## New Names and Shapes in Lighting

### Traditional Lamp Suppliers

- Sylvania
- Philips
- GE



### LED Suppliers

- Osram
- Lumileds
- Cree
- Bridgelux
- Nichia
- Seoul Semiconductor
- Toshiba
- Sharp
- Toyota Gosei
- Edison Opto
- and many more...

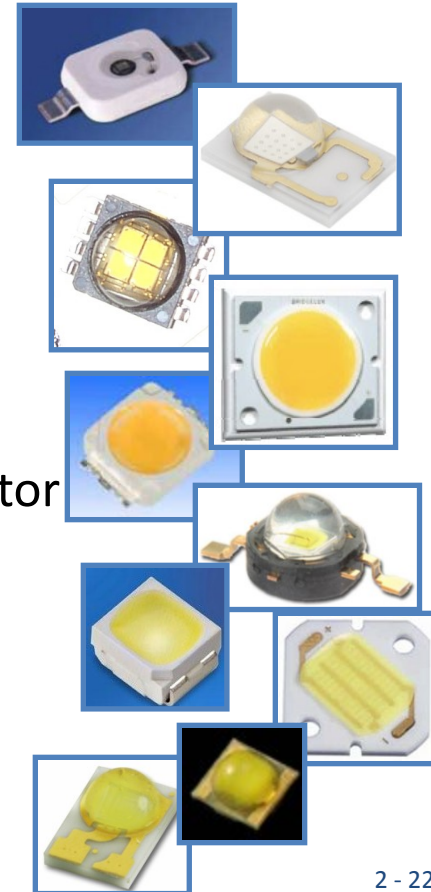

# What's Different

## Direct Color Creation

- For color lighting applications, traditional light sources use energy to create white light which then is filtered to create the desired color. The energy used to create the other colors is wasted

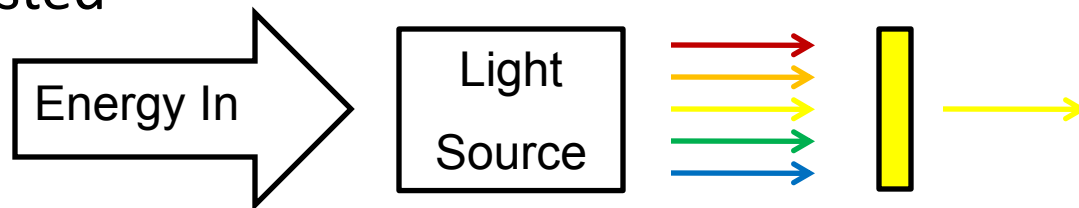

- LED light sources create the color directly leading to greatly improved energy efficiency



# What's Different

## Obsolescence — Part of the economic picture

---

- If Edison were alive today, he would certainly recognize his light bulb

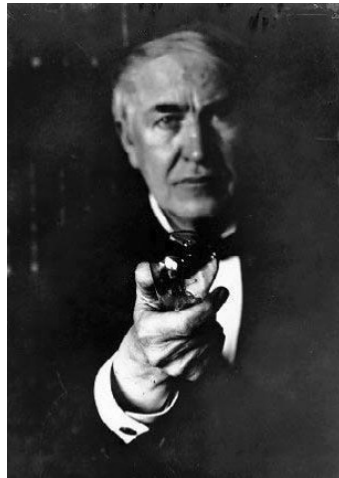

- If you owned this fixture, you could still get lamps for it



Early 20<sup>th</sup> century  
light fixture

# What's Different

## Obsolescence – Some things don't change

A 1942 Magazine ad for General Electric fluorescent lamps



A 2007 news release from a lighting magazine on an improved fluorescent lamp

Philips Lighting introduces revolutionary new Alto II linear fluorescent lamp technology

Date Announced: 06 Sep 2007

SOMERSET, N.J. - Philips Lighting Company, a division of Philips Electronics North America Corporation, an affiliate of Royal Philips Electronics (NYSE: PHG, AEX: PHI), proudly announces the introduction of ALTO II, its next-generation low-mercury fluorescent lamp technology for the professional lighting market.

Twelve years ago, Philips Lighting introduced its original ALTO technology and set a new industry standard by reducing the amount of mercury in its T8 fluorescent lamps to an industry low of 3.5 mg.

Today, through Philips Lighting's innovative technology, ALTO II T8 lamps now contain only 1.7 mg of mercury, an unprecedented 50 percent reduction from previous levels.

Now incorporated into a variety of 32-Watt Philips T8 lamps, lamps with ALTO II technology will continue to deliver the same high performance as the previous generation of ALTO lamps.



THE SAUNDERS LIVING POST 33

"General Electric MAZDA fluorescent lamps are Made to Stay Brighter Longer!"

"What makes you so sure?"

"They're checked and double-checked all the time. G-E MAZDA F lamps are subjected to hundreds of tests and inspections covering all important defects."

"By whom?"

"By a nationally known independent electrical testing laboratory as well as by experienced G-E inspectors."

"How many lamps are tested? Two or three thousand?"

"Nearly one million lamps every year . . . and remember, these tests are in addition to those made by G-E in its own factories."

**G-E MAZDA LAMPS**  
**GENERAL ELECTRIC**

*Made in the U.S.A.*

# What's Different

## Obsolescence – And some things do

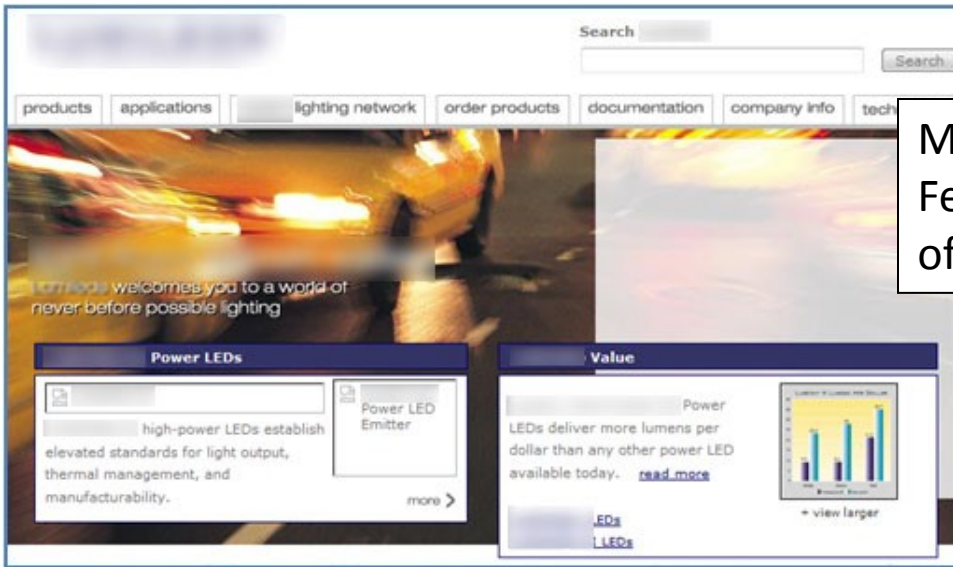

Manufacturer's web site from February 2006 showing the addition of a new line of LED devices

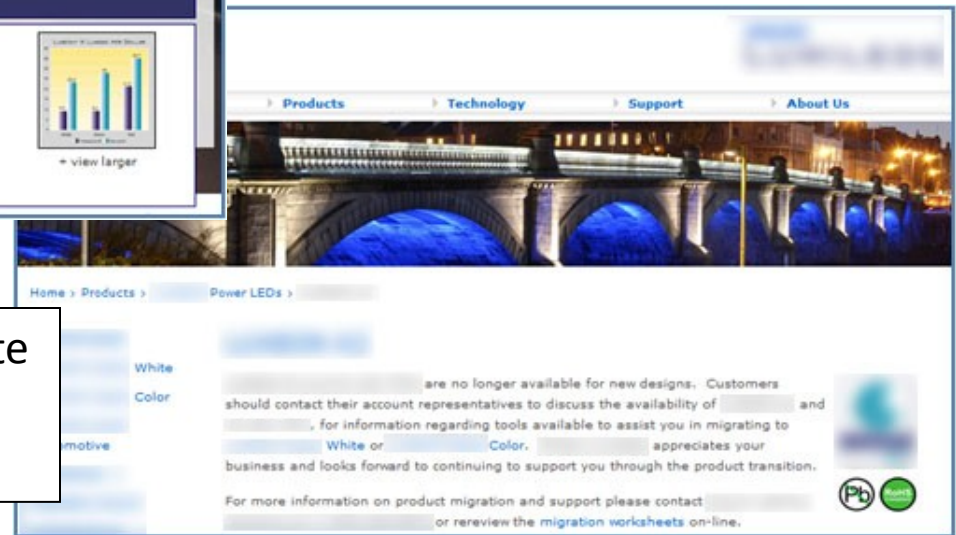

The same manufacturer's web site from March 2010 discontinuing that same line of LED devices

# Course Outline

---

1. Introduction – Why should I care about LEDs?
2. What's different – LED technology as compared to traditional light sources
3. Technology Limitations – Characteristics to be aware of with solid-state lighting
4. Environment – Its effect on LEDs
5. LED Products – Where to turn for guidance
6. Applications – Good ones and bad ones
7. Final Thoughts – Some general rules

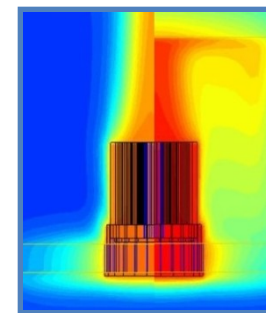

# Technology Issues

## Heat Generation

Power Conversion Comparison  
For Various Light Sources

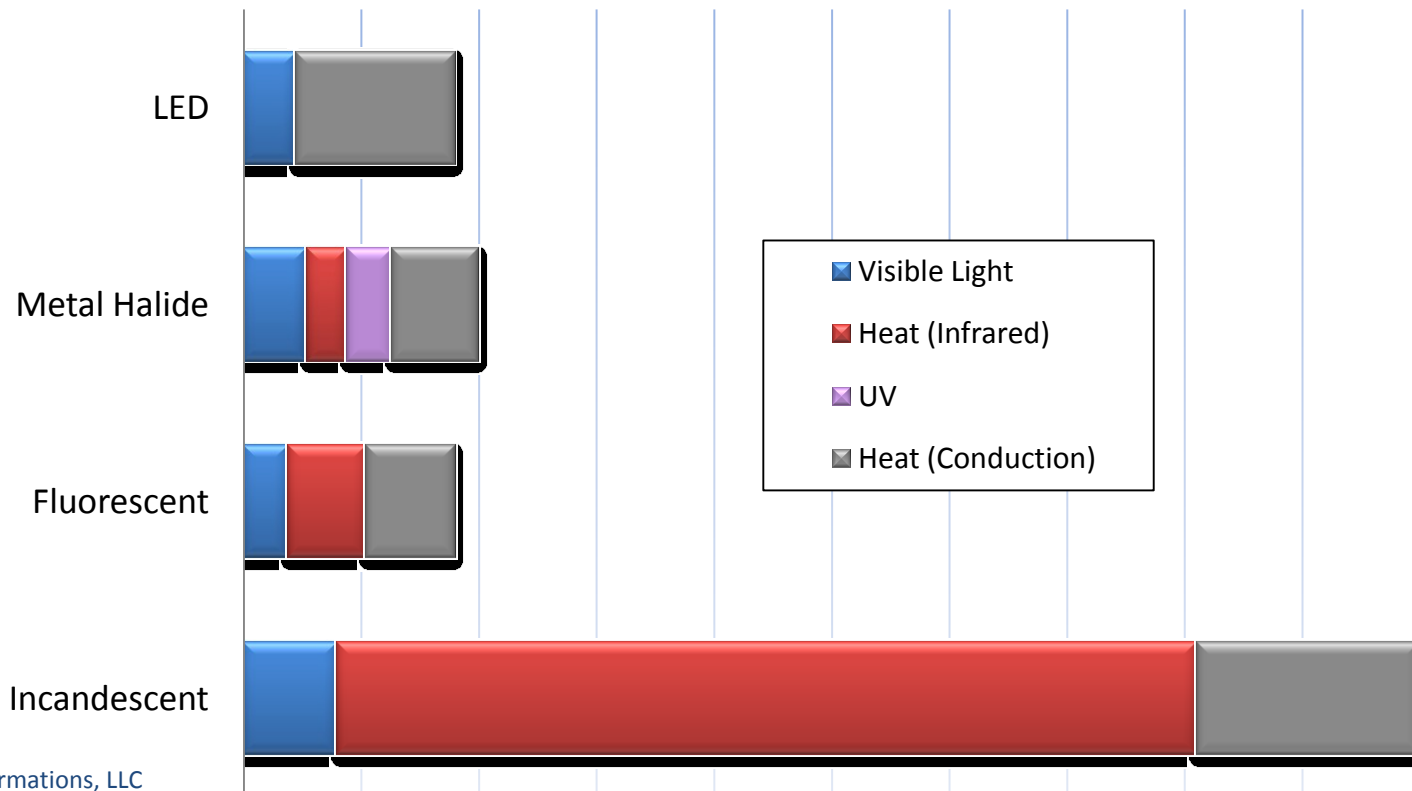

# Technology Issues

## Effect of Heat on Lifetime

LED Lifetime with ambient temperature of 55°C is 148,000 hours

LED Lifetime with ambient temperature of 85°C is 67,000 hours

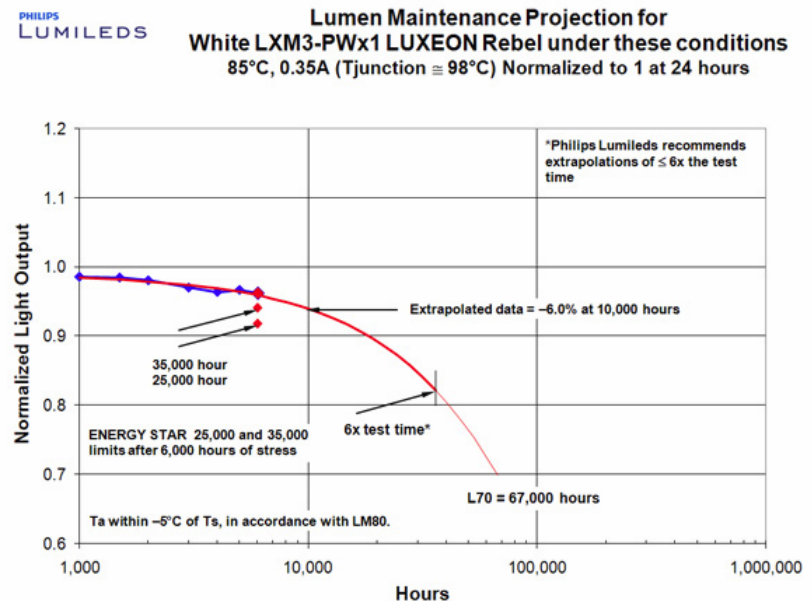
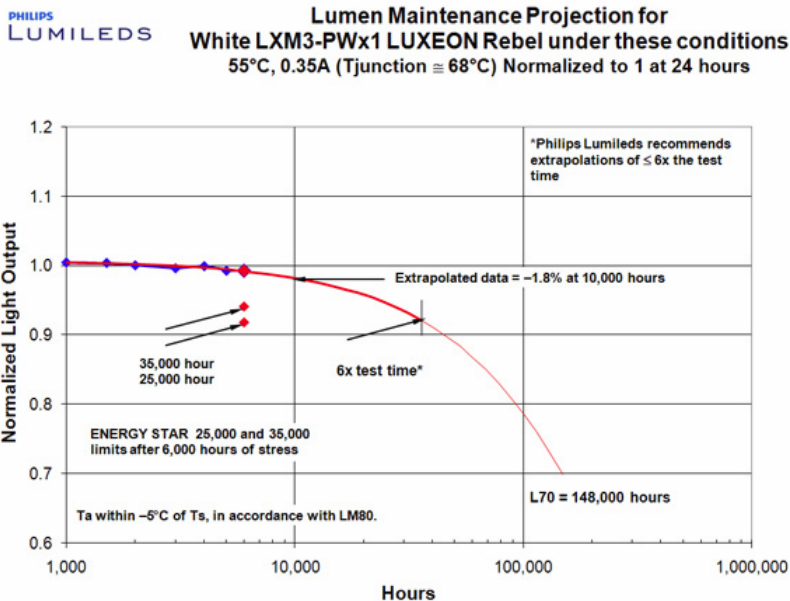

# Technology Issues

## Luminaire Orientation Can Effect Lifetime

Luminaire manufacturers must take desired orientations into account when designing thermal management system for products

LM-79 testing standard requires the luminaire be tested in the orientation in which it will be mounted

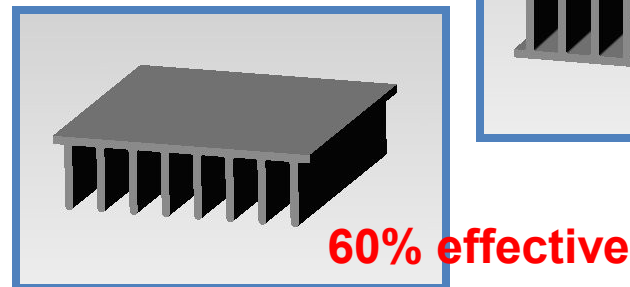
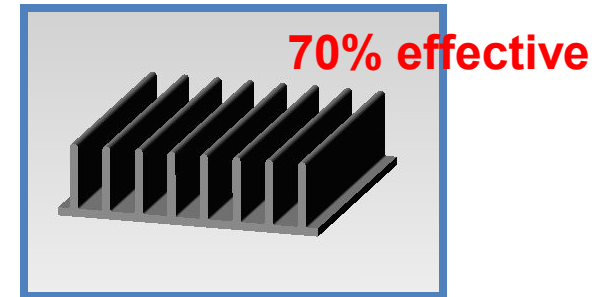
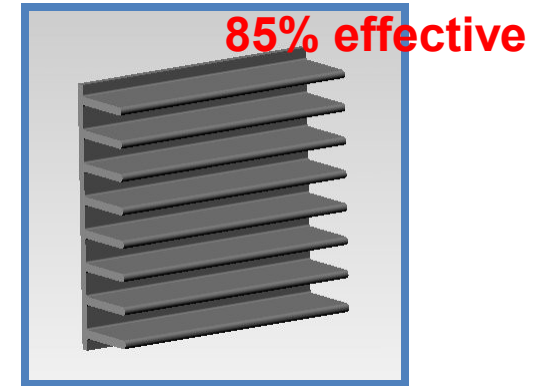

# Technology Issues

## Effect of Drive Current on Lifetime

At a junction temperature of 130°C lifetime is

28k hours (1 A)

33k hours (0.75A)

48k hours (0.350A)

Source: Lumileds Data Sheet

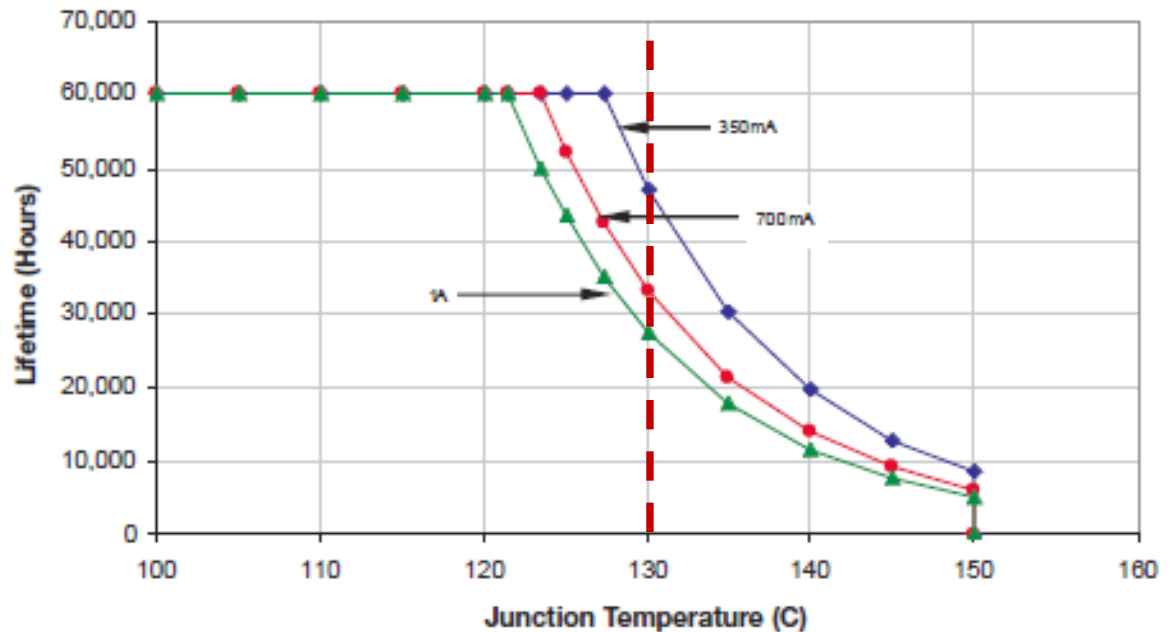

# Technology Issues

## Luminaire Lifetime – A Luminaire is a System

The failure of any one component can cause the entire system to stop functioning

Luminaire designers make trade-offs among the components, depending on the desired performance criteria – for example the number of LEDs (\$\$\$) versus drive current (lifetime)

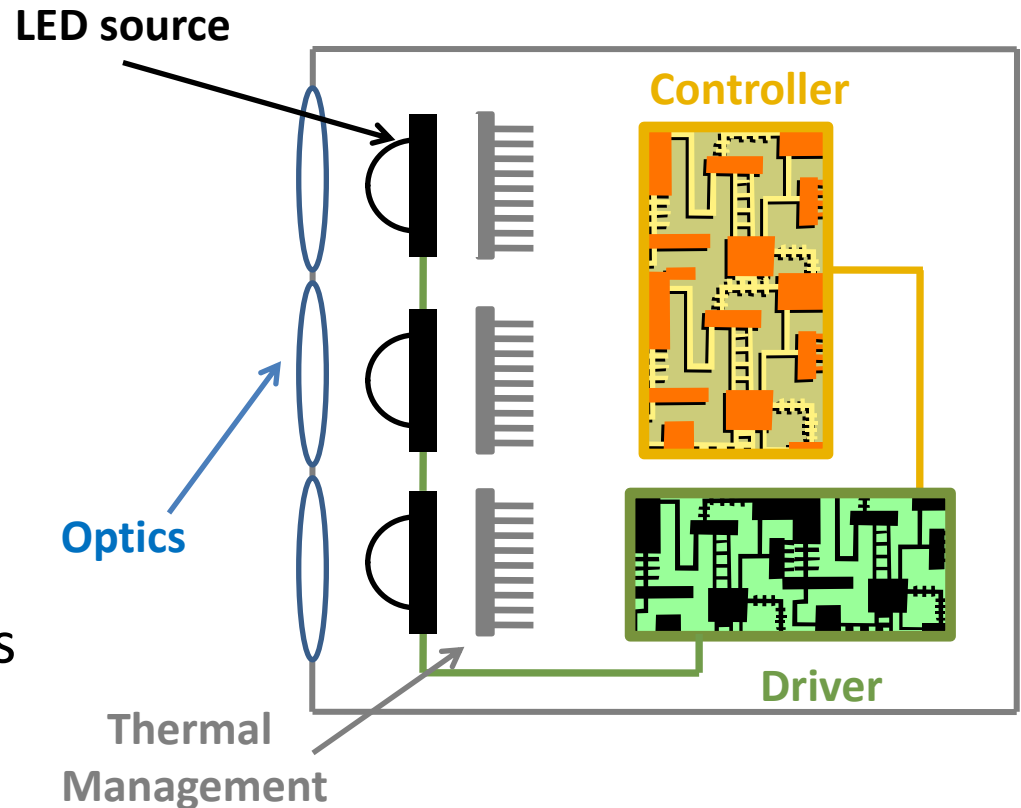

# Technology Issues

## Luminaire Lifetime – A Luminaire is a System

Two examples of failures caused by the driver



NJ Supermarket Freezer Case



City Center, Las Vegas

Source: LED Transformations

# Technology Issues

## Luminaire Lifetime – A Luminaire is a System

### Example of Optical Failure

From the original DOE Gateway Report:

- “At the prevailing average nighttime temperature in Minneapolis, the manufacturer projects that the luminaires would need to operate for several decades to reach this level of lumen depreciation [70% of original lumen output], estimating only about a 12% loss after 20 years.”

From a recent interim DOE Report:

- “Continuing decrease detected in average illumination on the ground, roughly 12% from initial after a few [15] months.”

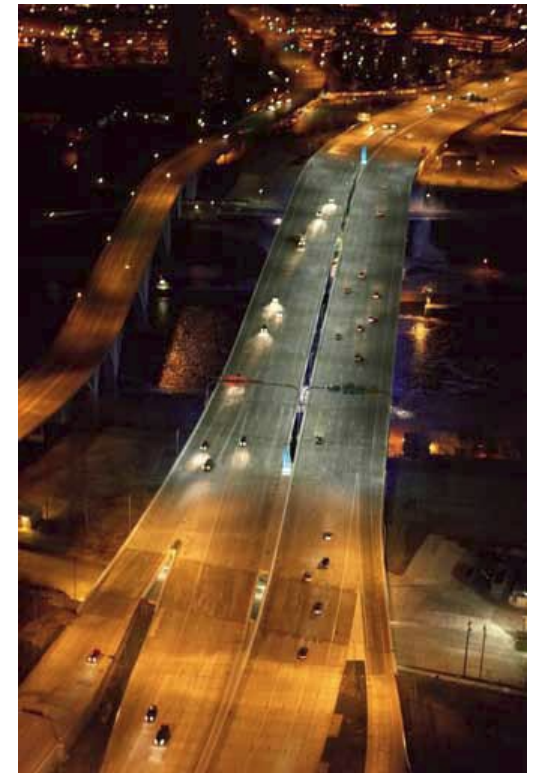

I-35 Bridge, Minneapolis, MN

# Technology Issues

## Color Matching / Color Shift

Supplier quality and testing is critical to successful projects

White is white is white?

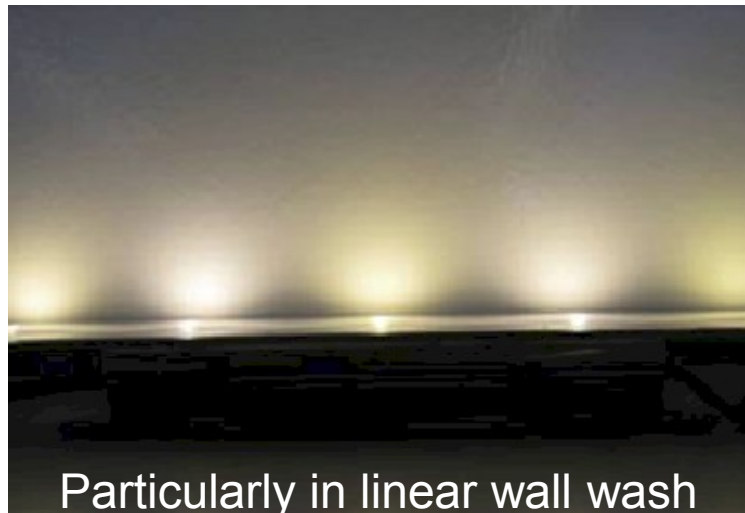

Particularly in linear wall wash applications, this lack of color consistency is non acceptable

Is blue?

Source: Cree

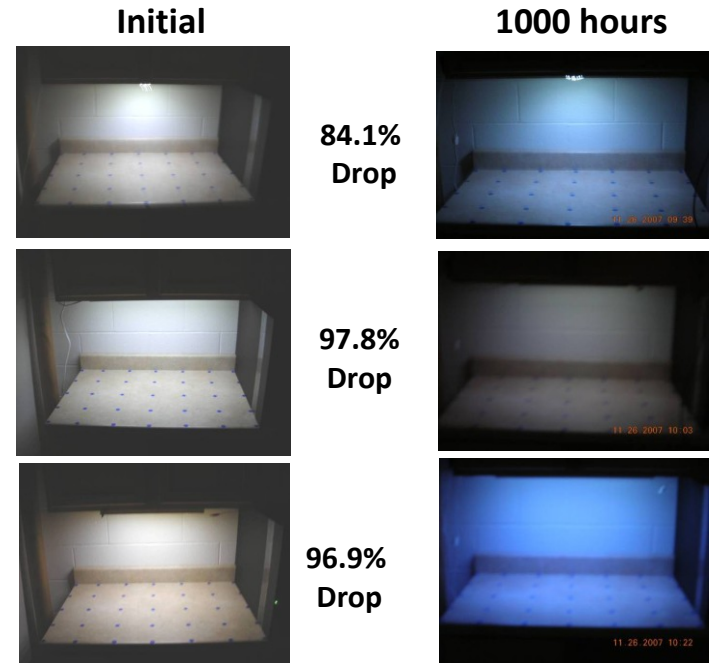

# Technology Issues

## Color Matching / Color Shift

What causes this shift from white to blue? Phosphor degrades faster than the blue die over time shifting light output to blue

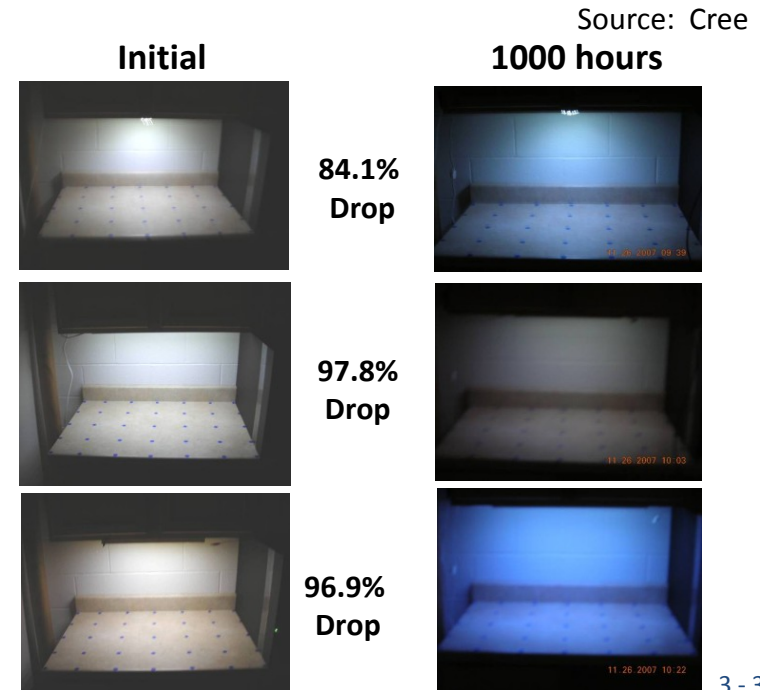
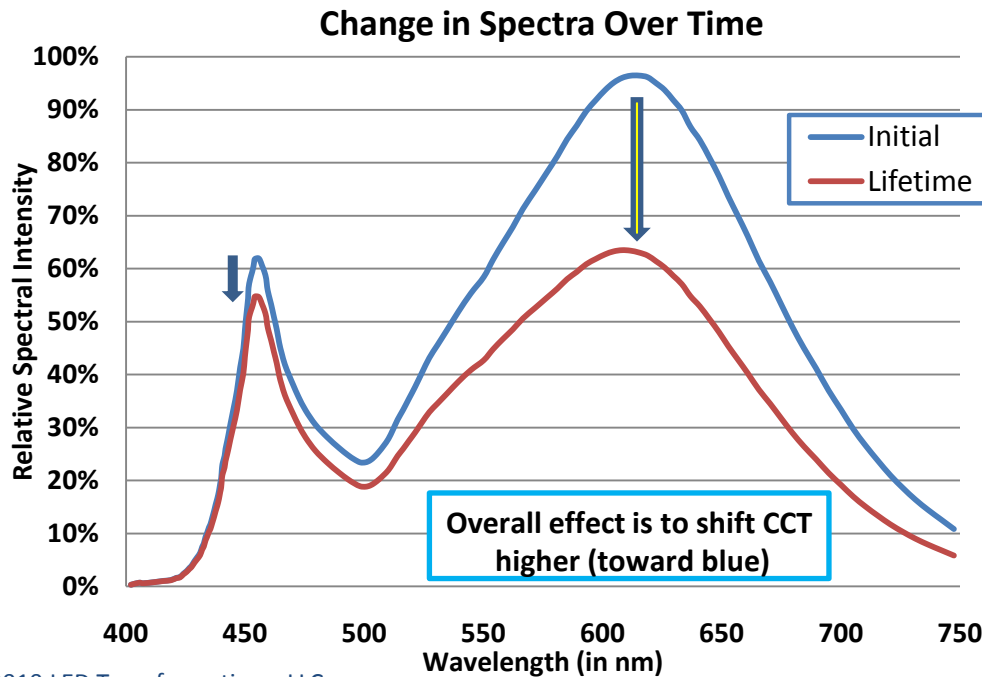

# Technology Issues

## Color Binning

Solid-state lighting manufacturers cannot control the exact color characteristics of LEDs when they are fabricated. To compensate they sort the finished LEDs into color bins.

Customers purchasing the widest range of bins get the lowest prices. It then becomes their responsibility to produce consistent color products. At least one manufacturer with a multi-chip product is mix/matching within the device to provide consistent color.

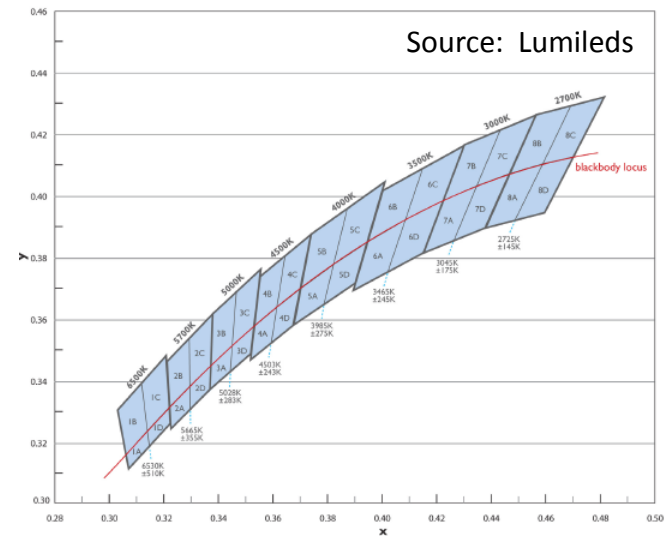

Source: Cree

3 - 37

# Technology Issues

## Standards

- LM-79-08 *Approved Method: Electrical and Photometric Measurements of Solid-State Lighting Products*
  - Describes testing procedure for evaluating light distribution from LED-based luminaires
- LM-80-08 *Approved Method for Measuring Lumen Depreciation of LED Light Sources*
  - Describes testing procedure for measuring lumen depreciation of LED devices
  - Does not describe how to evaluate data taken
- No approved standard available for driver lifetimes

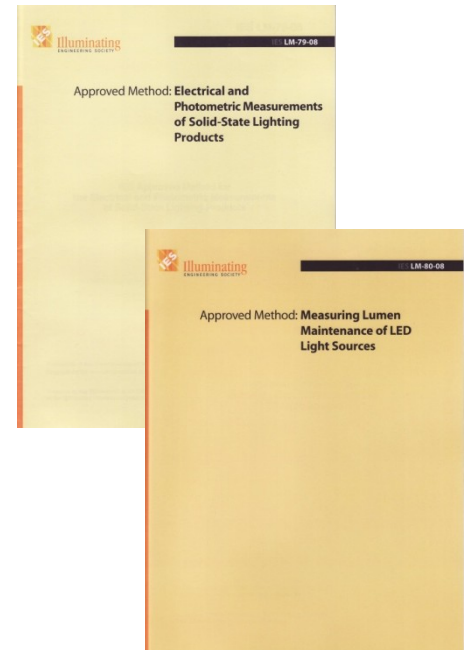

# Technology Issues

## LED Light Output – “Equivalent” to conventional sources?

- LED devices have highly directional light output unlike conventional light sources
- In directional fixtures such as downlights, this results in much less wasted light trapped in the fixture

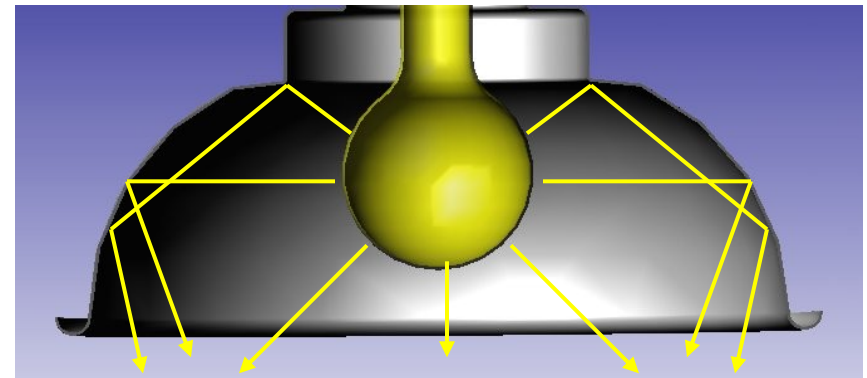
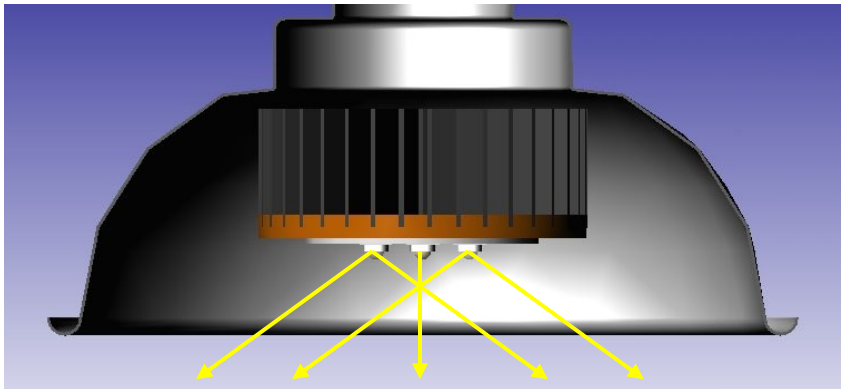
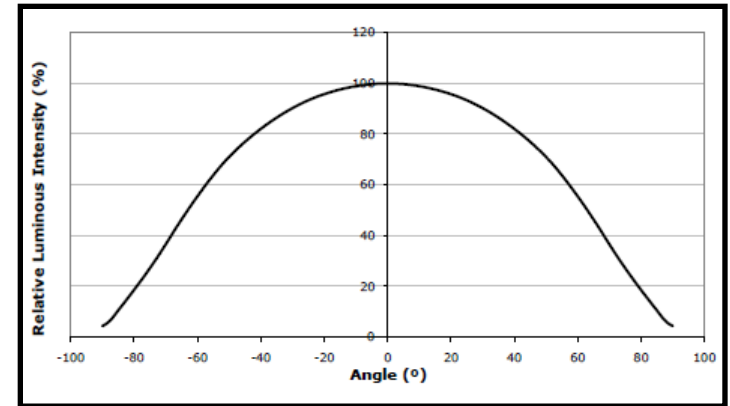

# Technology Issues

## The Word “Equivalent”

Incandescent lamp light output can be accurately conveyed by listing the lamp’s power (wattage)  
LED-based lamps do not show the same linear relationship due to the differences in device efficacy

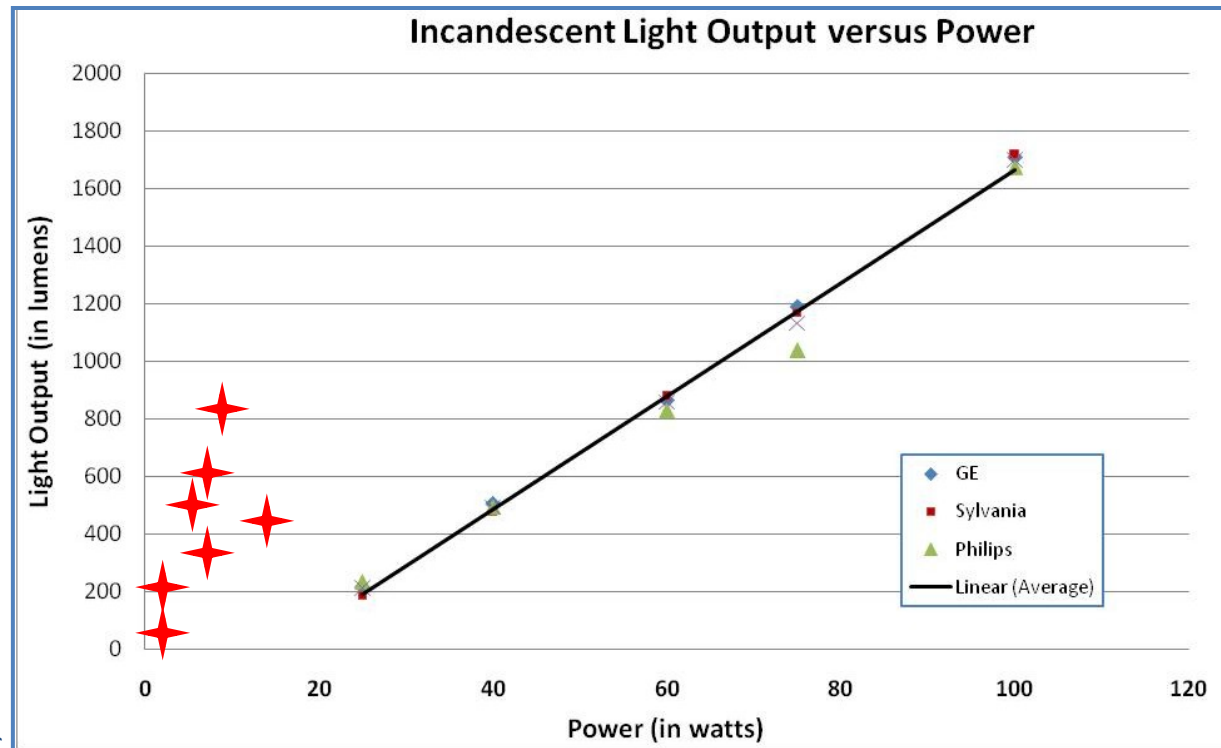

# Technology Issues

## LED Economics

---

However there are other parts of the lighting system besides the LED devices themselves that can fail or require maintenance

- Driver and Control Electronics (including dimmers, energy management systems) – component failures, lightning strikes and other electrical transients
- Optics – yellowing, cracking, voids, dirt buildup
- Heat sinks –bird droppings, insect nests
- Housings – mechanical stress, water intrusion, connectors

**How easy is it to repair/replace damaged components?**

# Technology Issues

## LED Economics

Many times, maintenance costs make or break the project

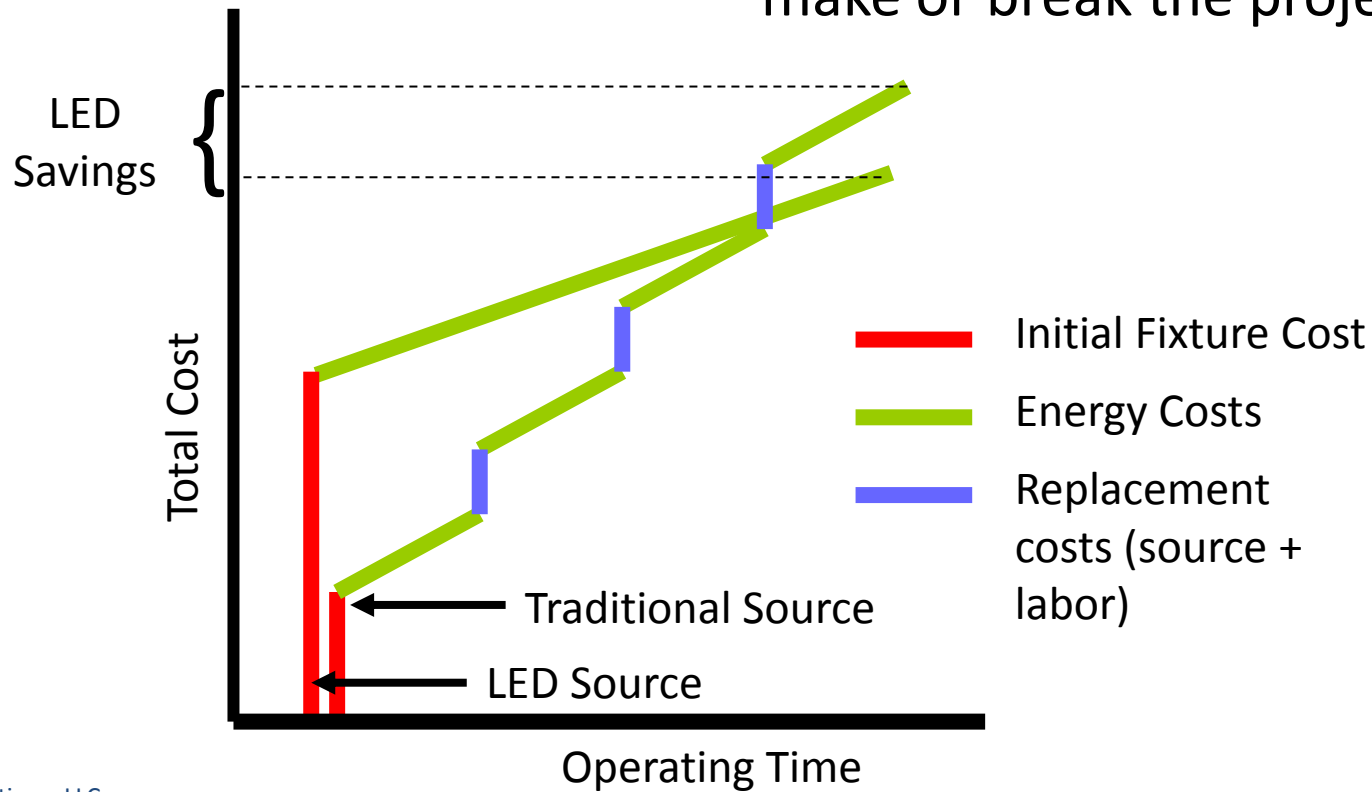

# Technology Issues

## Dimming

- Because LED systems work differently from those of incandescent lamps, dimming is often an issue
- LED drivers must be designed to be compatible with line-voltage dimmers (of which there are many types)
  - Many line-voltage products not compatible (like CFLs) with certain dimmers
  - Many low voltage LED systems with certain step-down transformers are not compatible with certain dimmers
- One dimmer manufacturer provides a matrix showing compatibility and functionality with various manufacturers' luminaires/or drivers



LED PRODUCT COMPATIBILITY MATRIX				
Manufacturer	Model	Description	Dimming Range?	Compatible Product?
Philips	16-kw LED driver	Driver	100% - 1%	YES
Philips	Stantum	Current Driver	Not Specified	YES
Philips	Stantum	PWM Driver	100% - 0%	YES
Philips	eW PowerCore	Strip Light	100% - 15%	YES
Philips	eW Profile - 11"	Under Cabinet Light	100% - 15%	YES
Philips	eW Profile - 41"	Under Cabinet Light	100% - 15%	YES
Philips	eW Downlight	Downlight	100% - 15%	YES
Philips	Downlight	6" Downlight	100% - 5%	YES
Philips	LR4	4" Downlight	100% - 20%	YES
Philips	LR6	6" Downlight	100% - 20%	YES
Philips	LR6 - 230V	6" Downlight	100% - 20%	YES
Philips	LR24	24" x 24"	100% - 5%	YES
Philips	Tetra dimming module	Driver	Not Specified	YES
Philips	LED Cove Light	Cove Light	100% - 3%	YES
Philips	Downlight	Downlight	Not Specified	YES
Philips	LED-18-356-120-D	Driver	100% - 0.1%	YES
Philips	LED-36-708-120-D	Driver	100% - 0.1%	YES
Philips	Calculla 10W	Downlight	N/A	YES
Philips	Calculla 20W	Downlight	N/A	YES
Philips	Par 30	Par 30 lamp	Not Specified	YES
Philips	OT Dim	Driver	100% - 0%	YES

# Technology Issues

## Total Light Output Over Time

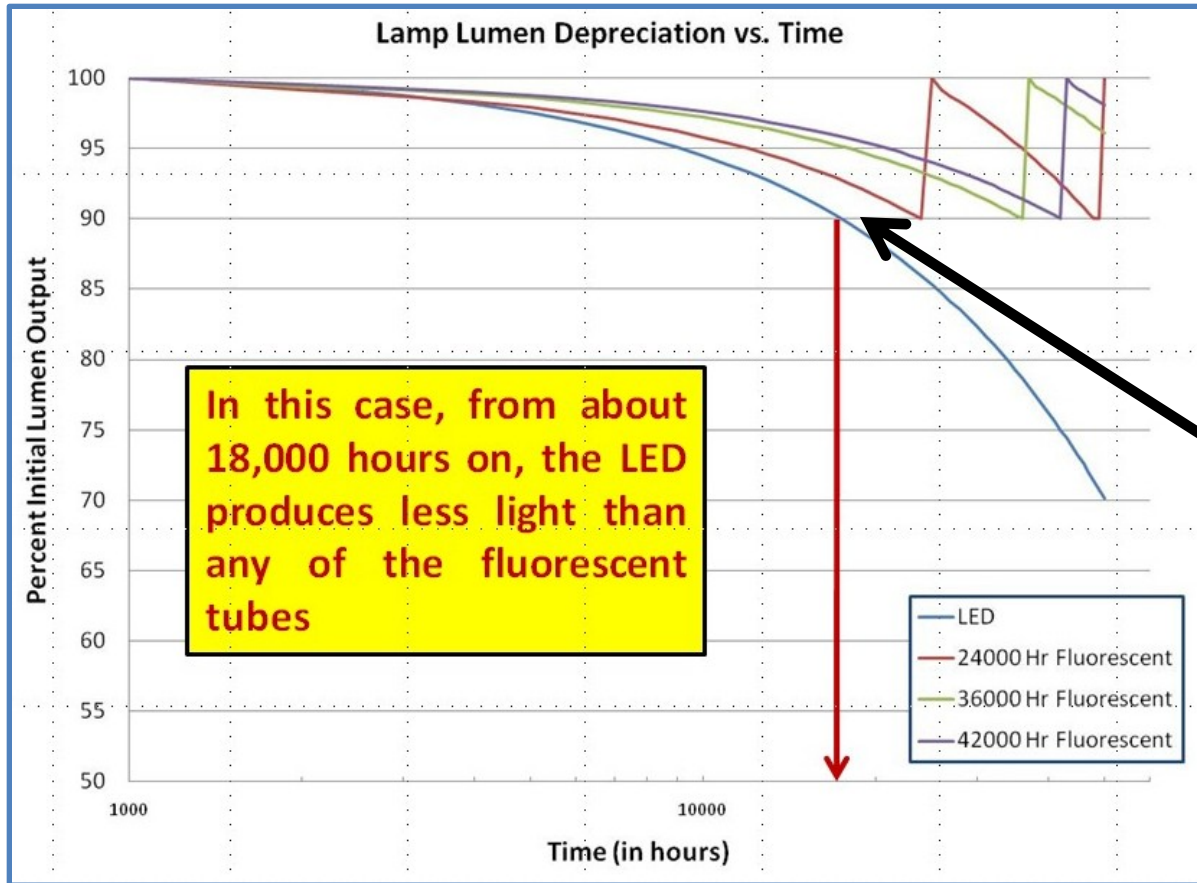

LED provides lower average light levels at this point

# Course Outline

---

1. Introduction – Why should I care about LEDs?
2. What's different – LED technology as compared to traditional light sources
3. Technology Limitations – Characteristics to be aware of with solid-state lighting
4. **Environment – Its effect on LEDs**
5. LED Products – Where to turn for guidance
6. Applications – Good ones and bad ones
7. Final Thoughts – Some general rules

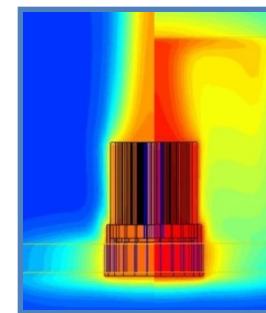

# Environmental

## Outdoors – Street & Area Lighting

Average nighttime temperature is well within reasonable limits for LEDs



Units typically do not operate during daylight hours

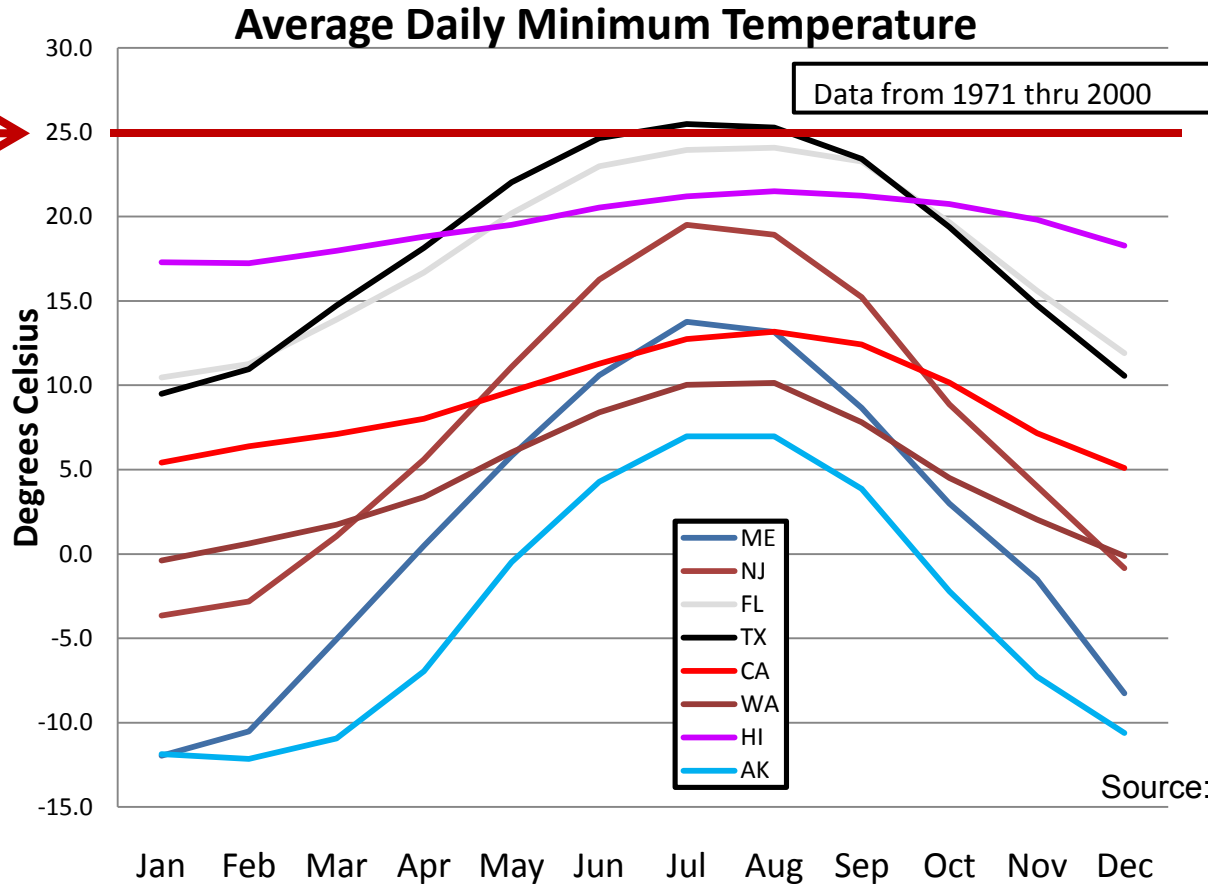

Source: Data - NOAA

# Environmental

## Cold Areas – Cold Storage & Freezer Cases



Light output increases slightly at lower temperatures

Source: Lumileds

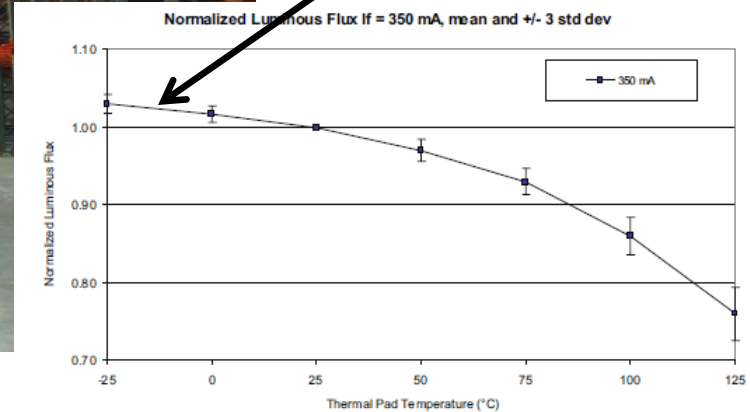

# Environmental

## Vandal Prone Areas

---

Which of these two devices looks more likely to survive a vandal attack in a school or prison?

Again taking advantage of LED's small size and directionality



LED Emergency Light

Source: Dual-Lite



Traditional Emergency Light

# Environmental

## Vibration Resistance

With no filament or electrodes to break, LEDs offer significant improvement over conventional light sources in high vibration and shock environments



Wingtip light of an Eclipse VLJ

Source: LED Transformations



Interior of the Boeing 787 Dreamliner

# Course Outline

---

1. Introduction – Why should I care about LEDs?
2. What's different – LED technology as compared to traditional light sources
3. Technology Limitations – Characteristics to be aware of with solid-state lighting
4. Environment – Its effect on LEDs
5. **LED Products – Where to turn for guidance**
6. Applications – Good ones and bad ones
7. Final Thoughts – Some general rules

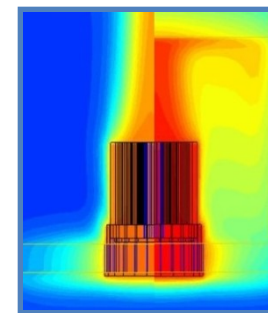

# LED Products

## One Way to Determine What's Good - CALiPER

---

The DOE CALiPER program supports testing of a wide array of SSL products available for general illumination, using industry-approved test procedures. CALiPER test results:

- Guide DOE planning for SSL R&D and market introduction activities, including ENERGY STAR® program planning
- Support DOE GATEWAY demonstrations and technology procurement activities
- Provide objective product performance information to the public in the early years, helping buyers and specifiers have confidence that new SSL products will perform as claimed
- Guide the development, refinement, and adoption of credible, standardized test procedures and measurements for SSL products

# LED Products

## CALiPER – MR-16 Example

- Dozens of manufacturers are offering LED replacements for halogen MR-16 lamps.
- Many of these claim to be “equivalent” to 35W or 50W halogen lamps. However...

*“In CALiPER testing to date, the performance of LED MR16 replacement lamps varied greatly. Power usage for the LED replacements is considerably lower than for halogen MR16 lamps. However, light output and intensity for the tested LED products falls significantly short of the halogen benchmark levels, limiting the usefulness of LED MR16 lamps as a one-for-one replacement in typical highlighting and accent applications.”*

Source: CALiPER Benchmark Report Nov. 2008

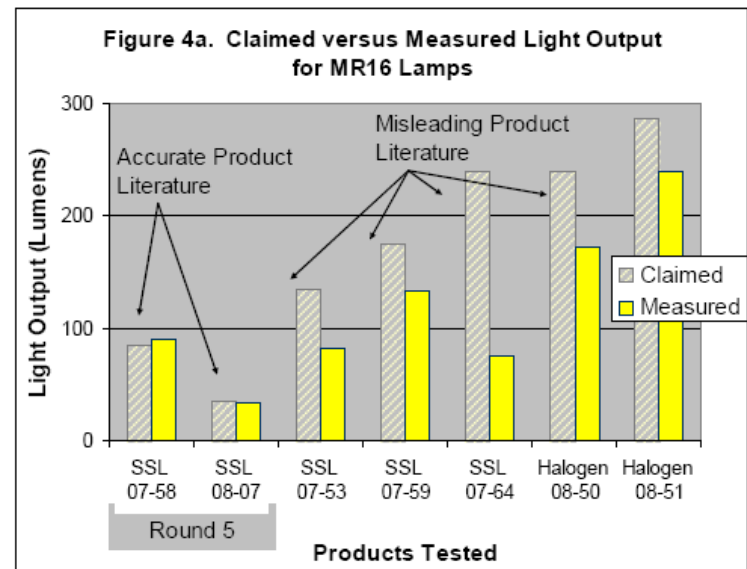









5 - 52

## CALiPER – Replacement Lamps

Results from Round 9 CALiPER testing (October 2009) show that a large number of LED product manufacturers are still not providing accurate performance data

CALiPER results are available at:  
<http://www1.eere.energy.gov/buildings/ssl/caliper.html>

Table 4. CALiPER ROUND 9 – Replacement Lamp Manufacturer Claims

Sample Type and CALiPER Reference	Manufacturer Claims	Actual Performance Level (e.g. Light Output, Efficacy, CBCP, Beam Angle)	Provides Accurate Product Reporting	
Replacement Lamp (MR16) 09-80	<i>180 lm, (54-69 lm/W) Eq. to 35W halogen</i>	165 lm, 50 lm/W 304 cd, 31° Less than average 20W halogen	NO	
Replacement Lamp (R20) 09-78	230 lm, (32 lm/W) 7W=35W	263 lm, 42 lm/W 944 cd, 25° Exceeds average 35W halogen	YES	
Replacement Lamp (R30) 09-64	<i>Replaces 45W (450 lm, 128 lm/W) CRI=84, 30° beam</i>	186 lm, 54 lm/W CRI=71, 695 cd, 20° Less than 20W eq.	NO	
Replacement Lamp (PAR30) 09-76	<i>Eq. to 75W Incand. 550 lm, 70 lm/W 60-70° beam</i>	468 lm, 59 lm/W 190 cd, 100° Eq. to 50W R30	NO	
Replacement Lamp (PAR38) 09-63	<i>Replaces 45W (450 lm, 90 lm/W)</i>	289 lm, 58 lm/W 902 cd, 22° Less than 25W eq.	NO	
Replacement Lamp (A-lamp) 09-60	<i>260 lm, (34.6 lm/W) Replaces 40W incandescent</i>	251 lm, 34 lm/W Eq. to 25W incandescent	NO	
Replacement Lamp (A-lamp) 09-77	155 lm, (22 lm/W) Eq. to 25W	208 lm, 33 lm/W Eq. to 25W incandescent	YES	
Replacement Lamp (Candelabra) 09-65	<i>Replaces 40W (320 lm, 220 lm/W)</i>	67 lm, 45 lm/W Less than average 15W incandescent	NO	
Replacement Lamp (Candelabra) 09-74	30 lm, (12 lm/W) "Uses less energy than a 15W candelabra"	31 lm, 17 lm/W Eq. to 7-15W night light	YES (possibly misleading)	

# LED Products

## Another Way

### Lighting Facts Label

Clear Representation of

- Light Output
- Power
- Efficacy
- Color
  - CRI
  - CCT

Results verified by third party testing using LM-79 testing methods

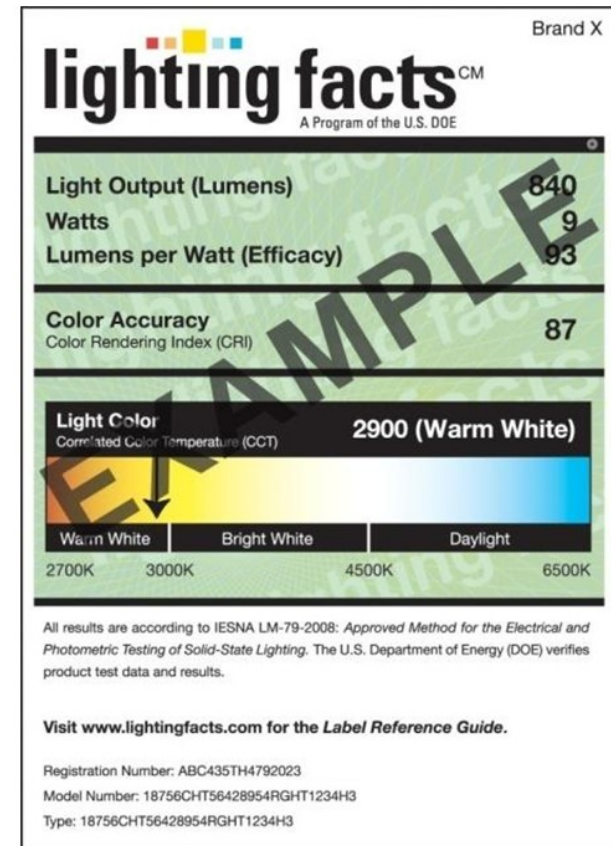

# LED Products



## Energy Star – SSL Luminaires General Requirements

---

### Highlights

- Indoor luminaires shall have a minimum CRI of 75
- Requires **zero** off-state power draw for the fixture; PFC  $\geq$  0.7 residential, PFC  $\geq$  0.9 commercial
- Lumen Maintenance:
  - Residential – 25k hrs Indoor, 35k hrs Outdoor
  - Commercial – 35k hrs commercial
- Luminaire efficacy requirements ratchet up over time to take into account technology improvements
- CCT shall be within one of the following groups: 2700K, 3000K, 3500K, 4000K, 4500K, 5000K, 5700K, 6500K

# LED Products



## Energy Star – Integral LED Lamp Standard

- Standard was published December 3, 2009 and becomes effective August 10, 2010
- Scope
  - Omnidirectional replacement lamps
  - Directional replacement lamps
  - Decorative lamps
  - Non-standard lamp forms
  - ANSI lamp bases
- Not included in standard
  - Linear fluorescent replacement lamps
  - HIS replacement lamps



ENERGY STAR® Program Requirements for Integral LED Lamps  
ENERGY STAR Eligibility Criteria  
Final – December 3, 2009

Below are the product criteria for ENERGY STAR qualified Integral LED Lamps - Version 1.0. A product must meet all of the criteria in order to be qualified as ENERGY STAR.

1) SCOPE: These criteria apply to integral LED lamps<sup>2</sup>, defined as a lamp with LEDs, an integrated LED driver, and an ANSI standardized base designed to connect to the branch circuit via an ANSI standardized lampholder/socket. These criteria include integral LED lamps of non-standard form, and those intended to replace standard general service incandescent lamps, decorative (candelabra style) lamps, and reflector lamps. Other types of replacement lamps may be added in the future as improvements to LED technology make LED use in other replacement lamp types viable.

2) DEFINITIONS

A. **A2LA**: American Association for Laboratory Accreditation.  
B. **ANSI**: American National Standards Institute.  
C. **ASTM**: American Society for Testing of Materials.  
D. **CIE**: Commission Internationale de l'Eclairage (translated International Commission on Illumination).  
E. **Color rendition**: The effect the spectral characteristic of the light emitted by the LED has on the color appearance of the objects illuminated by it is called color rendition. The color rendering index (CRI) is defined in terms of a comparison of the spectral tri-stimulus values of the objects under test illumination and standard illumination according to the recommendations of CIE Publication No.13.3-1995.  
F. **Correlated Color Temperature (CCT)**: The actual color of the LED is called the color temperature and is defined in terms of the spectral tri-stimulus values (color coordinates) according to the recommendations of IESNA LM-16-93. For color coordinates near the blackbody loci, the correlated color temperature, measured in Kelvin (K), is used.  
G. **CSA**: Canadian Standards Association.  
H. **Duv**: the closest distance from the Planckian locus on the (u', 2/3 v') diagram, with + sign for above and - sign for below the Planckian locus.  
I. **ETLT**: elevated temperature life test.  
J. **Integral LED lamp**: a lamp with LEDs, an integrated LED driver, and an ANSI standardized base designed to connect to the branch circuit via an ANSI standardized lampholder/socket.  
K. **IEC**: International Electrotechnical Commission.  
L. **IESNA**: Illuminating Engineering Society of North America.  
M. **ISTM**: in situ temperature measurement test.  
N. **LED array**: An assembly of LED packages on a printed circuit board or substrate, possibly with optical elements and additional thermal, mechanical, and electrical interfaces. The device does not contain a power source, does not include an ANSI standardized base, and is not connected directly to the branch circuit.  
O. **LED driver**: A power source with integral LED control circuitry designed to meet the specific requirements of a LED lamp or a LED array.  
P. **LED lumen maintenance (L<sub>70</sub>)**: The length of time declared by the manufacturer at which 70% lumen maintenance of any large sample of LEDs is reached.  
Q. **LED module**: A component part of an LED light source that includes one or more LEDs connected to the load side of LED power source or LED driver. Electrical, electronic, optical, and mechanical components may also be part of an LED module. The LED module does not contain a power source and is not connected directly to the branch circuit.  
R. **LED package**: An assembly of one or more LED dies that contains wire bond connections, possibly with an optical element and thermal, mechanical, and electrical interfaces. The device does not include a power source, does not include an ANSI standardized base, and is not connected directly to the branch circuit.  
S. **Lumen maintenance**: The luminous flux at a given time in the life of the LED and expressed as a percentage of the initial luminous flux.  
T. **MacAdam color ellipse**: An elliptical region of chromaticity coordinates that is defined using a centroid, a tilt angle relative to a horizontal axis, and a defined level of variance. Such a region defines what chromaticity

<sup>2</sup> ANSI/IESNA RP-16-05, Addendum "a", IESNA, 2008.

# LED Products

## Lighting for Tomorrow – 2009 LED Winners

*Architect LED Flat Panel  
MaxLite*

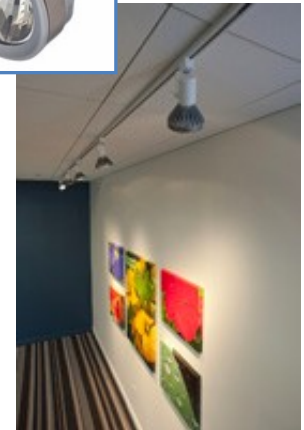
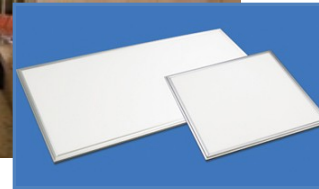

*Par 38 Track Fixture  
Cree LED Lighting*

*eW® Cove QLX Powercore  
Philips Color Kinetics*



*Eco-Counter - 120V LED Under Cabinet Task Light  
CSL - Creative Systems Lighting*



# LED Products

## Next Generation Luminaires™

The Next Generation Luminaires™ (NGL) Solid State Lighting (SSL) Design Competition was created to recognize and promote excellence in the design of energy-efficient LED commercial lighting luminaires

*Stile Styk* by STILE,  
a brand of SPILIGHTING Inc



*Evolve™ LED R150*  
by GE Lighting Solutions



*VizorLED* by Philips Wide-Lite



*CURVE*  
by Finelite, Inc

# LED Products

## Gateway Program – Demonstrations in Various Applications

Demonstrations showcase high-performance LED products for general illumination in a variety of commercial and residential applications. Results provide real-world experience and data on state-of-the-art solid-state lighting (SSL) product performance and cost effectiveness.



Freezer Case Lighting  
Albertsons, Eugene OR



Street Lighting  
Oakland, CA



Downlights Lane City  
Tour of Homes  
Eugene, OR



Raley's Supermarket  
West Sacramento, CA



FAA Research Center  
Atlantic City, NJ

# LED Products

## And Finally...

---

### Third-party test results

- Don't just take the luminaire manufacturer's word
- Reputable photometric test labs
  - DOE certified for CALiPER testing
  - NVLAP certified for LM-79 testing

### Warranty Policy

- Is there a written end-of-life policy? How will spares be made available?
- Do all system components from SSL manufacturers have a warranty and labor to fix/replace?
- How long is the warranty? What exactly is covered?

# Course Outline

---

1. Introduction – Why should I care about LEDs?
2. What's different – LED technology as compared to traditional light sources
3. Technology Limitations – Characteristics to be aware of with solid-state lighting
4. Environment – Its effect on LEDs
5. LED Products – Where to turn for guidance
6. Applications – Good ones and bad ones
7. Final Thoughts – Some general rules

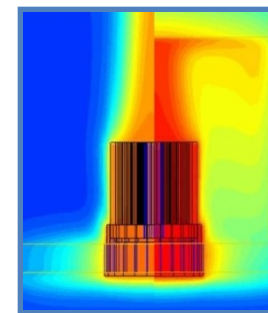

# Applications

## Downlight – Good



Friendly's Restaurant, Westfield MA

Incandescent 5,135 W



LED 948W



LED (2 Years Later)

Makes use of directionality

Source: Cree

# Applications

## Street Lighting – Good



Source: Eric Hugaard, Ruud Lighting

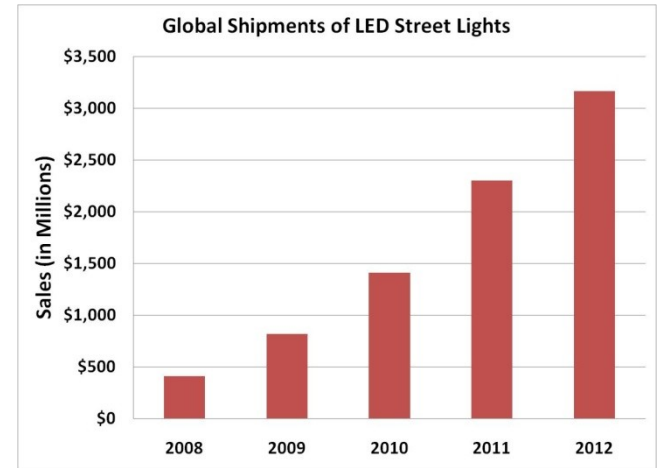

Source: Photonics Industry and Technology Development Association

15% energy savings over previous HPS

**Makes use of directionality**

# Applications

## Cove Lighting – Good



Makes use of small form factor

LED Cove Lighting In Resort Casino

-30% Energy Saved vs. Proposed Neon

-No Mercury, Recyclable = Green Value for Hotel

Source: GreenLight Initiative

6 - 64

Maintain. Improve. Evolve.  
EVERY SQUARE FOOT.

# Applications

## Task Lights / Bollards – Good

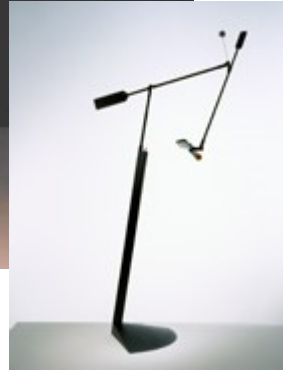

**Makes use of directionality  
and small form factor**

# Applications

## Incandescent Replacements – Good and Bad

Wide range of product performance available, from good to poor



Makes use of small form factor and high efficacy

# Applications

## Fluorescent Replacements – Depends

2x4 parabolic louver  
Fluorescent T8

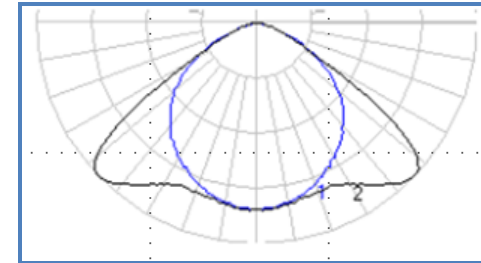

0.92 LLD

0.95 LDD

0.88 BF (n/a)

0.65 W/ft<sup>2</sup>

25 fc (average)

1.9 max/min

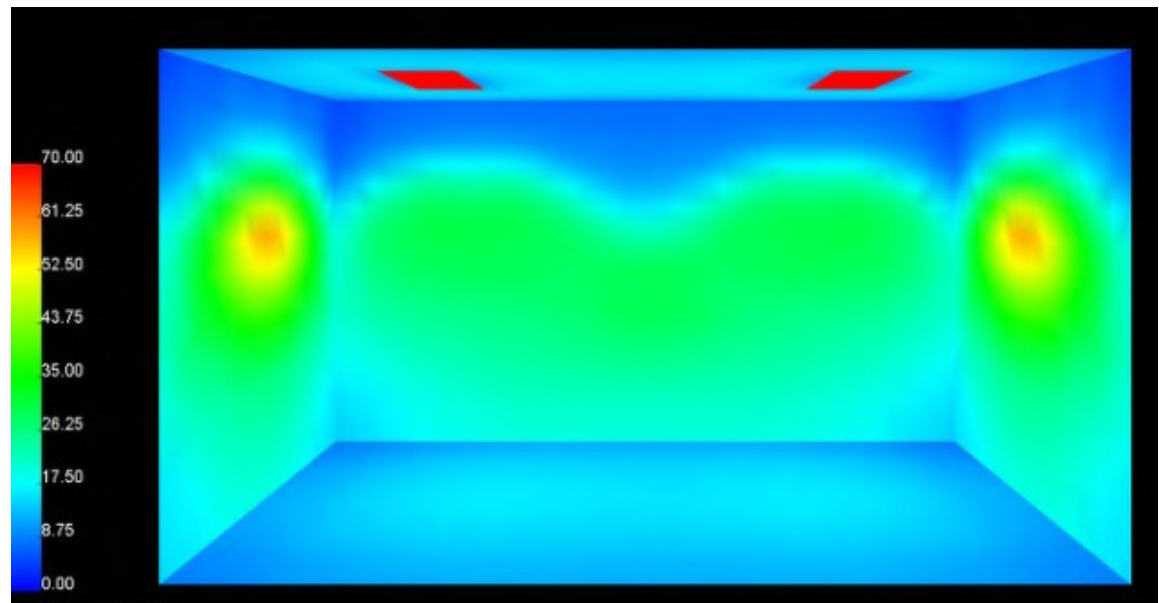

Source: Tuenge & Myer, DOE PNNL

6 - 67

# Applications

## Fluorescent Replacements – Depends

2x4 parabolic louver  
LED Replacements

0.70 LLD  
0.95 LDD  
1.00 BF

0.44 W/ft<sup>2</sup>  
10 fc (average)  
2.3 max/min

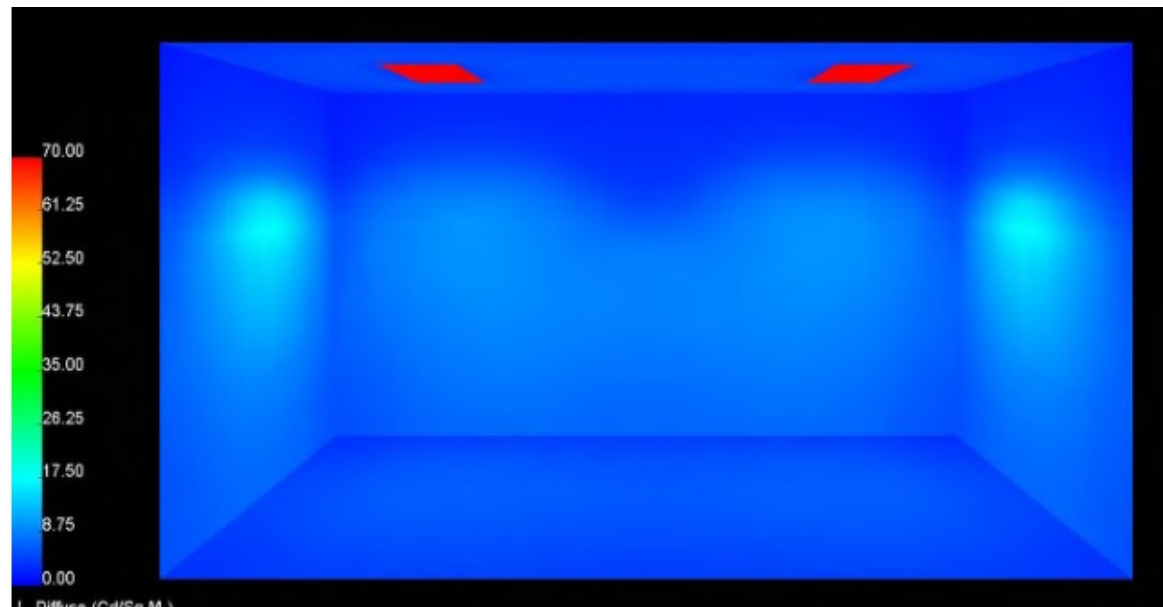
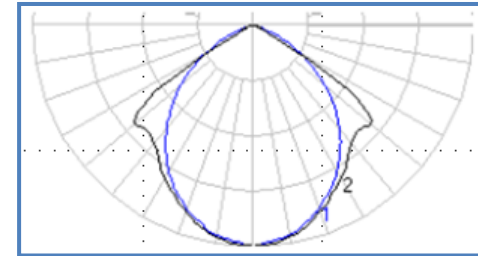

Source: Tuenge & Myer, DOE PNNL

6 - 68

# Applications

## Fluorescent Replacements – Depends

2x2 parabolic  
Fluorescent T8U

0.92 LLD

0.95 LDD

0.94 BF (n/a)

0.64 W/ft<sup>2</sup>

20 fc (average)

2.5 max/min

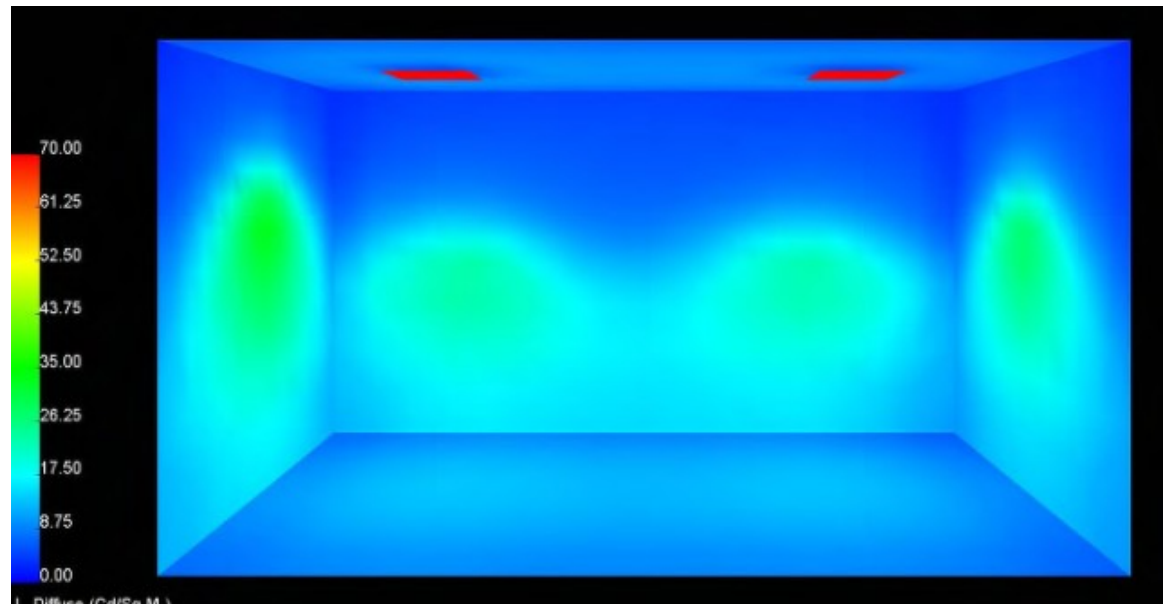
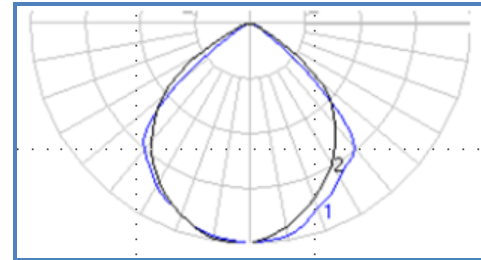

Source: Tuenge & Myer, DOE PNNL

6 - 69

# Applications

## Fluorescent Replacements – Depends

2x2 lensed  
Integral LED

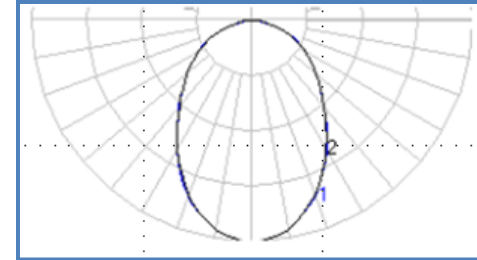

0.70 LLD  
0.95 LDD  
1.00 BF

0.45 W/ft<sup>2</sup>  
17 fc (average)  
2.6 max/min

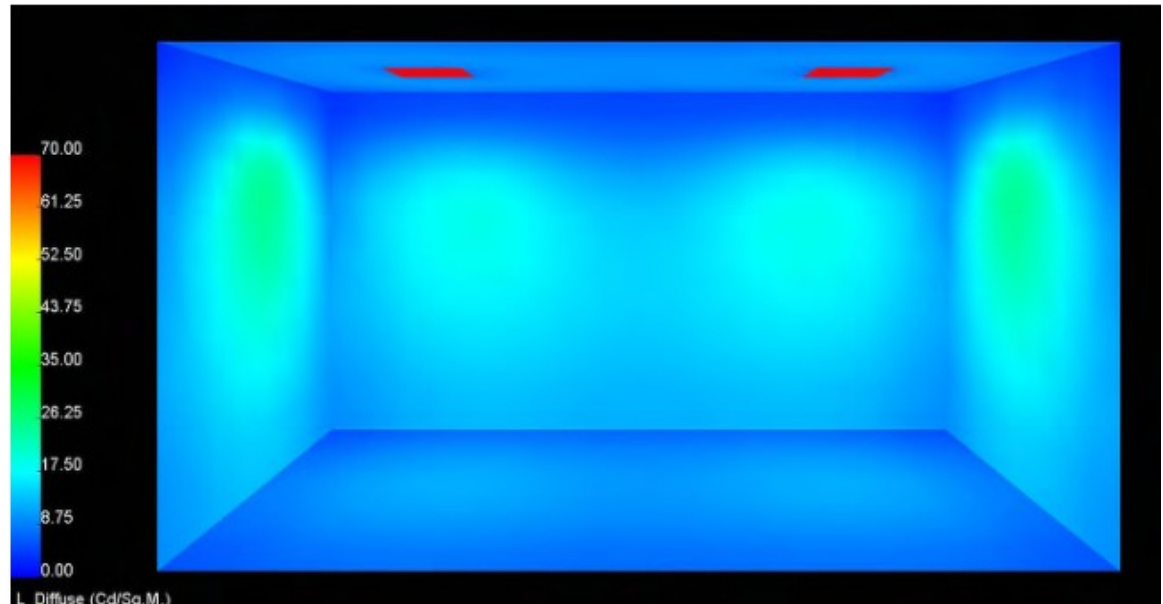

Source: Tuenge & Myer, DOE PNNL

6 - 70

# Applications

## High Power MR-16s – Not So Good

- The design envelope for a standard MR-16 allows for a limited surface area to dissipate heat generated by the LEDs
- This, in turn, limits the light output possible for the device based on present LED efficacy values and required lifetime – 50W MR-16 not possible

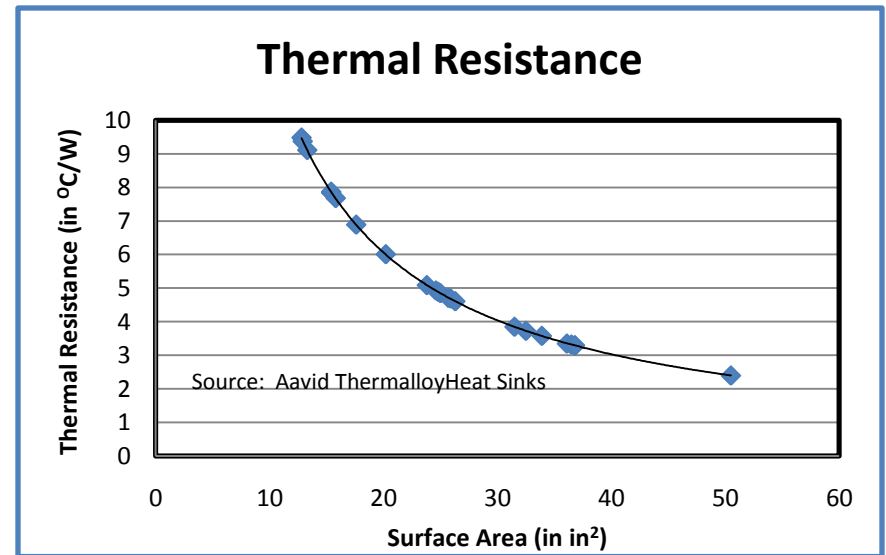
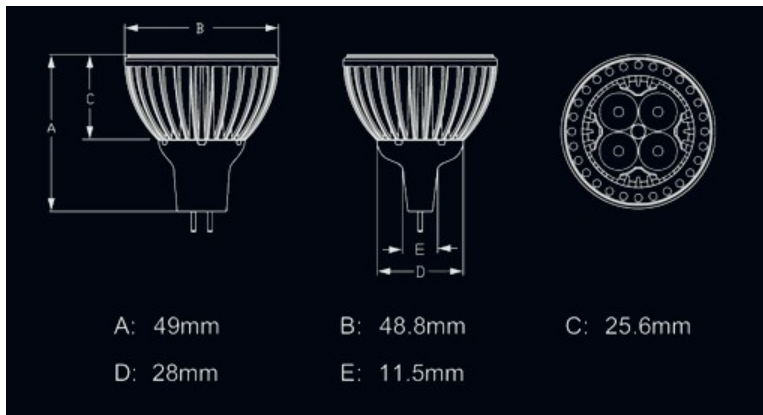

# Applications

## High Power MR-16s – Not So Good

### Halogen versus LED-based MR-16 test results

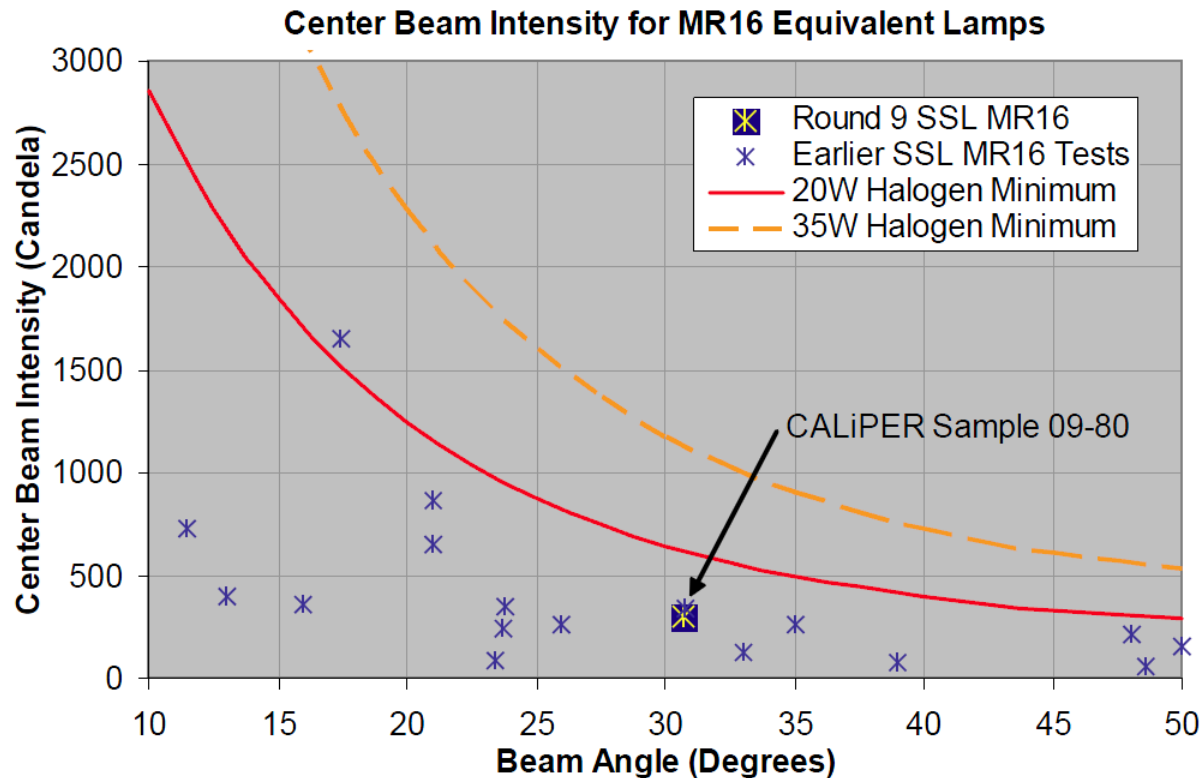

# Course Outline

---

1. Introduction – Why should I care about LEDs?
2. What's different – LED technology as compared to traditional light sources
3. Technology Limitations – Characteristics to be aware of with solid-state lighting
4. Environment – Its effect on LEDs
5. LED Products – Where to turn for guidance
6. Applications – Good ones and bad ones
7. **Final Thoughts – Some general rules**

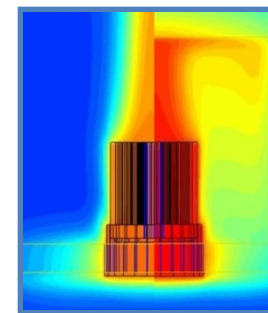

# Final Thoughts

## From the User's Side

---

1. Temperature range specification for operation
  - How does that compare with the maximum junction temperature for the LEDs used in the product?
2. Luminaire manufacturer
  - How long has the manufacturer been in business? What business?
  - Does the firm use brand name LEDs?
  - Were the LEDs tested to LM-80?
3. Warranty
  - Life expectancy of product (Energy Star requires at least a 3-year warranty)
  - What replacement costs are covered (e.g. installation labor, shipping, etc.)
  - What performance elements are warranted (e.g. CCT shift, lumen output, luminaire efficiency, etc.)

# Final Thoughts

## From the User's Side

---

### 4. Power Issues

- Power Factor
- Off-state power consumption (Energy Star requires  $< 0.5W$ )
- Is the unit dimmable? With what controllers?
- Step-down transformer compatibility for low-voltage retrofit products

### 5. Does it have a UL / ETL / CSA / applicable safety mark?

### 6. Chromaticity

- Shift over time/temperature
- Variation from fixture to fixture

### 7. Luminaire performance

- Fixture efficiency (in lumens/Watt)
- Delivered lumens (not just LED device performance)
- IES files
- LM-79 test results from approved third party laboratory
- Lumen maintenance

# Final Thoughts

## From All Sides

---

Do not underestimate the use and practical application of simple  
**COMMON SENSE**<sup>Note 1</sup>

- If it seems too good to be true, it probably is
- If you can't understand how a product could do "that," there is a high likelihood that it probably "doesn't"
- If nobody else's product does "that" maybe this product does not do it either

Note 1 Requires ownership of at least a limited quantity

# Final Thoughts

## Where are LED-Based Products Appropriate?

- Outdoor area & street lighting
- Downlighting
- Task lighting
- Display lighting
- Cove lighting
- “Architainment” environments
- Other applications that make use of LED’s unique attributes
  - Small size
  - Directionality
  - Low temperature performance
  - Improved secondary optics performance due to die size
- As LED efficacy improves, applications will expand



Source: Kelly Gordon, PNNL

# Final Thoughts

## You Can't Ignore It

---

Solid-state lighting technology is coming whether you like it or not, leaving you with two choices:

- Embrace it wisely
  - Learn all you can about it
  - Choose a pilot project to try it out
  - Acknowledge that as with all electronics, LED products will always be less expensive tomorrow
- Ignore it foolishly
  - Dismiss it as a fad
  - Keep saying “It isn’t ready yet”
  - Find excuses to avoid testing it

# Final Thoughts

## A Lesson From History

---

- Think of how the microprocessor has changed the world over the last 30 years.



- The lighting world is about to undergo a change not seen since the invention of the incandescent lamp, and driven by that same semi-conductor industry.

**Are you going to be ready for it?**

# Final Thoughts

## DOE Resources

---

The Department of Energy offers a number of useful program to insure that quality products are available to the public and to further the adoption of efficient LED lighting

- SSL Quality Advocates
- Gateway Demonstration Program
- CALiPER
- Lighting for Tomorrow
- Next Generation Luminaires
- Municipal Consortium on LED Street Lights
- Technical Information Network for Solid-State Lighting
- DOE Funded R&D Programs

[www.ssl.energy.gov](http://www.ssl.energy.gov)

# Acknowledgements

---

Support for the development and presentation of this educational seminar was provided by the US Department of Energy

U.S. DEPARTMENT OF  
**ENERGY**

Energy Efficiency &  
Renewable Energy

# Thank you for your time!

## QUESTIONS??

**This concludes The American Institute of Architects  
Continuing Education Systems Program**

Dr. John (Jack) W. Curran  
President LED Transformations, LLC  
PO Box 224 Stanton, NJ 08885 (908) 437-6007  
[jcurran@ledtransformations.com](mailto:jcurran@ledtransformations.com)

US Department of Energy  
[www.ssl.energy.gov](http://www.ssl.energy.gov)